



TEMPEST
lighting inc.

Tornado 2200



Touchdown! The Tempest Tornado is a weather-resistant enclosure designed to provide optimum lifetime and operating conditions for automated luminaires used in exterior locations.



The Tornado 2200 provides protection and style for a number of popular moving-head fixtures up to 1200W. All Tornado enclosures feature a clear dome, in which the luminaire has complete freedom of movement, and a fiberglass base, containing Tempest's patented Digital Enclosure Control (DEC) electronics, fans and heating elements.

By monitoring the interior temperature of the enclosure, the DEC system controls humidity and dew point, eliminating condensation and corrosion, 24/7. When the fixture is running, Tornado's powerful fans exchange the filtered air inside the enclosure every 3-4 seconds, ensuring long lamp and equipment life.

Tornado models have been tested and approved for many luminaire types, and the list is growing all the time. If your light is not on the list, we'll test it and approve it as part of your project.

Tornados have been saving our customers money for years, in deserts, through winters, and at sea, all over the world.

Enclosure

Non-corrosive fiberglass composite, stainless steel and aluminum. Acrylic optically clear 250° x 360° projection globe, 36" (915mm) diameter.

For Luminaire Type: Martin MAC 2000

Mounting

Two parallel 1 5/8" x 13/16" Unistrut. Mount with suitable standard Unistrut hardware, or order 4 sets per enclosure of either of the following Tempest mounting kits. Tempest kits are made from stainless steel and aluminum hardware.



4900.MB *Stainless Steel Unistrut channel nut, bolt and washer. Four required per enclosure.*



4900.MC *Stainless Steel Unistrut channel nut, bolt and pipe clamp, for pipes 1.5" (38mm) to 2" (50mm) OD. Four required per enclosure.*

Security

4 Heavy-Duty stainless steel key draw latches, 2 with secondary catch. Stainless steel eyebolt for safety bond.

Orientation

Normally base-down. Other orientations require minor modifications and must be advised with order.

Finish

Urethane Coating, to AAMA603-8 standard. Standard colors beige, white or gray. Custom colors to special order.

Climate Control

Patented Digital Enclosure Control (DEC) System, microprocessor controller and display controls humidity and dewpoint.

Cooling

Filtered fresh air cooled using four dual-speed DC fans, fused and polarity protected. One washable filter.

Heating

Proportionally controlled 750 watt heater coil dries intake air and provides up to 30°F temperature rise above ambient.

Protection

Fixture over-temperature DPDT relay.

Diagnostics

Self-diagnostics of microprocessor inputs/outputs

Control Wiring

DMX control cable feedthrough exterior conduit access box. Cable by others.

Electrical

Connections landed in exterior conduit access box.

Enclosure – hardwired on site, 200-240VAC, 50/60Hz, 5amps (max)

Light Fixture: Americas: NEMA L6-20 receptacle provided

Asia/Europe: CE17 16amp receptacle provided

Dimensions

36"(dia) x 50"(h), weight 62lb* - 914mm(dia) x 1270mm(h), 28kg*

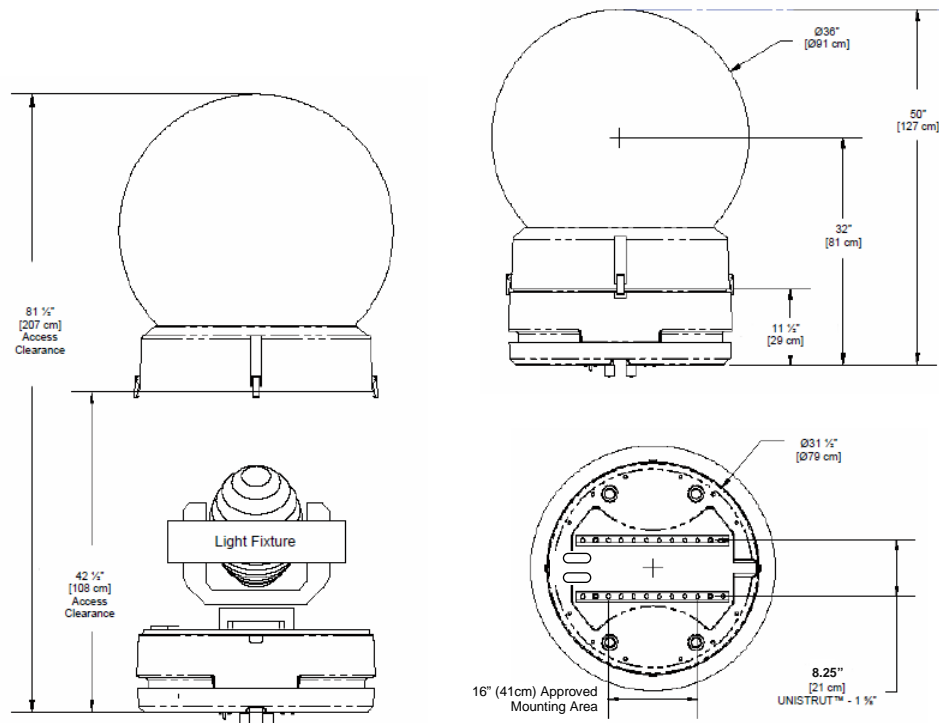

Shipping (crated)

42"x42"x63"(h), weight 300lb* - 107 x 107 x 160cm(h), 136kg*

Schedule B Export Code: 8536.30.0000

* Weights may vary, due to fittings required for different luminaire types

Specification

Unit shall be a Tempest Lighting Tornado 2200. The housing shall be non-corrosive fiberglass composite. Further, the unit shall possess filtered forced air ventilation in combination with heater and controlled by a microprocessor with a temperature display. Unit shall be ETL listed to U.L. standard 508 for wet locations and be a NEMA type 3R. The unit shall have above ground connection ports, compression latches with padlock rings, and may be secured to its mounting via stainless steel eye bolt, making it highly theft resistant. Unit shall provide a power cutoff to fixture in case of high temperature inside enclosure. Units shall control cool-down rate of lighting fixture by use of heater. Unit shall have a projection globe with 360° of pan and 260° of tilt. The fixture shall be identified as The Tornado Enclosure manufactured by Tempest Lighting, Inc, of N Hollywood, CA, USA.

Ordering Information

The following information must be provided with each order:

- Luminaire type, model number and lamp power
- Orientation (base-down, base-up, or other angle)
- Base Color: White, Gray, Beige or Custom

Approvals

ETL and cETL listed to UL Standard 508 (7/11/05), CE. NEMA Type 3R.



NEMA type 3R

This product is covered by US Patent Number 6,352,358.

In the interest of continuous product improvement, specifications are subject to change without notice

Tempest Lighting, Inc.,

5401 Bevis Avenue, Sherman Oaks, CA 91411, USA

www.tempestlighting.com info@tempestlighting.com

t: +1 818 787 8984

f: +1 818 787 4994

