

User Manual and Installation Guide

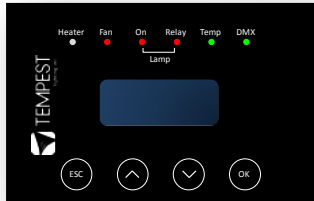

*Now featuring
DEC3™ on
select models -
the latest,
greatest in
enclosure
control*



September, 2010

Blizzard 6550, 6560 Series Projector Enclosures

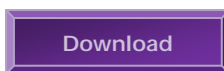

*You can download a copy of this manual at
<http://www.tempestlighting.com/products.html#blizzard>*

Tempest Lighting Inc.
13110 Saticoy Street
North Hollywood, CA 91605, USA

Tel +1 818 787 8984
Fax +1 818 982 5582
info@tempestlighting.com

In the interest of continuous product improvement, the information in this document is subject to change without notice. Neither Tempest Lighting, Inc. nor its representatives or agents may be held liable for expense or injury arising from it.

© Tempest Lighting Inc. All Rights Reserved



Declaration of Conformity

This is to certify that the following products

- 6550.INBlizzard, DEC3 Enclosure Control, 230V
- 6555.INBlizzard Stretch, DEC3 Enclosure Control, 230V
- 6556.INBlizzard X-Stretch, DEC3 Enclosure Control, 230V
- 6560.INBlizzard, Force-cooled, 230V
- 6565.INBlizzard Stretch, Force-cooled, 230V
- 6566.INBlizzard X-Stretch, Force-cooled, 230V

are in Compliance with the following standards or specifications according to the EMC Directive 89/336/EEC.

- EN55015, EN61000-3-4, EN61000-3-5, EN61000-4-2, EN61000-4-3, EN61000-4-4, pr
EN61000-4-5, EN61000-4-6, EN61000-4-8, EN61000-4-11

and are in compliance with the following standards or specifications according to the Low Voltage Directive 73/23/EEC.

EN60598-1

This declaration is made by the manufacturer

Tempest Lighting, Inc.
 13110 Saticoy Street, Unit C
 North Hollywood, CA 91605, USA

This declaration is based on tests that were conducted on the submitted samples of the above mentioned products. Detailed results can be referred to test reports CET.TE200909 and LVT.Te200909.

Dated: October 26th, 2009
 Signature
 Tempest Lighting Inc



Table of Contents

Topic	Section
Introduction	1
Enclosure Dimensions	1.1
Maximum Projector Dimensions and Power	1.2
INSTALLATION.....	2
Safety and Warnings	2.1
Tools and Equipment.....	2.2
Mounting the Enclosure.....	2.3
Base-up or Base-down Operation?.....	2.4
Mounting the Projector.....	2.5
Wiring	3
Electrical Preparation	3.1
Wiring for Fan-Only Versions.....	3.2
Wiring for DEC3 Versions	3.3
DMX Connections.....	3.4
DEC3 Control System.....	4
Operating Modes	4.1
DEC3 Control Parameters	4.2
RDM and RDM Integration.....	4.3
Control Interface	4.4
Control Interface Operation	4.5
Operation – Fan-Only Versions.....	5
Routine Maintenance	6
Troubleshooting	7
Warranty	8
Registration.....	9

1 Introduction

The Blizzard™ Projector Enclosure

Thank you for purchasing the Blizzard digital projector enclosure. It will serve you for many years, protecting your 5-15,000 ANSI Lumen projectors from the elements. Although primarily intended for outdoor environments, the design of the Blizzard is such that it can satisfy many other needs. Not only will it protect against hostile outdoor conditions, but also against particulate, smoke, and other indoor conditions that can shorten the life of your digital projector. In addition, you may specify a Blimp option, with soundproofing and a remote fan, for silent operation in theatres and classrooms.

Products Covered by this Manual

6550.US	Blizzard, DEC3 Enclosure Control, 120V
6550.IN	Blizzard, DEC3 Enclosure Control, 230V
6555.US	Blizzard Stretch, DEC3 Enclosure Control, 120V
6555.IN	Blizzard Stretch, DEC3 Enclosure Control, 230V
6556.US	Blizzard X-Stretch, DEC3 Enclosure Control, 120V
6556.IN	Blizzard X-Stretch, DEC3 Enclosure Control, 230V
6560.US	Blizzard, Force-cooled, 120V
6560.IN	Blizzard, Force-cooled, 230V
6565.US	Blizzard Stretch, Force-cooled, 120V
6565.IN	Blizzard Stretch, Force-cooled, 230V
6566.US	Blizzard X-Stretch, Force-cooled, 120V
6566.IN	Blizzard X-Stretch, Force-cooled, 230V
6590.BL	Blizzard Remote Fan/Soundproofing Kit

Using This Manual

Please read this manual in its entirety before starting work. All the information contained is important, and should be read carefully before proceeding. Heed all warnings and advisories.

Icon Key:

- ① Valuable information
- ⚡ Electrical Warning
- ⚠ Safety Information

1.1 Dimensions and Weight

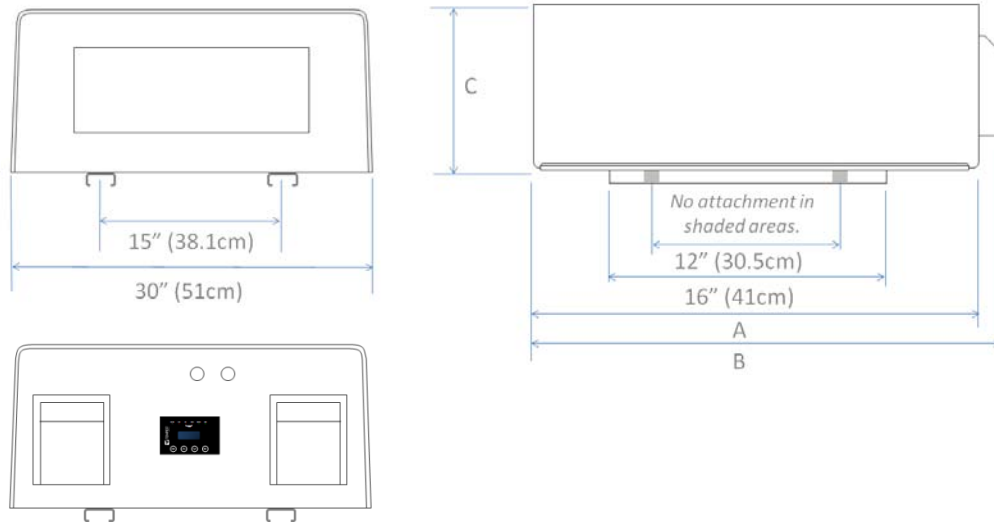

Maximum Projector Dimensions

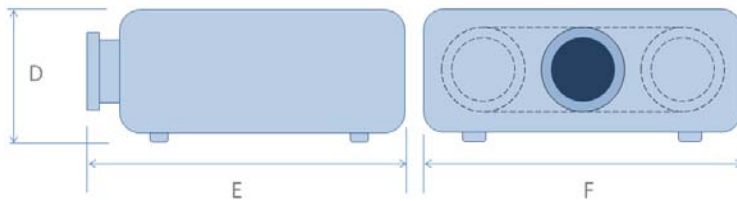







Model #	Description	A	B	C	D	E	F	Weight
6550.US	Blizzard, DEC3 Enclosure Control, 120V	31"/79cm	33"/84cm	14"/36cm	10"/25cm	24"/61cm	26"/66cm	77lb/35kg
6550.IN	Blizzard, DEC3 Enclosure Control, 230V	31"/79cm	33"/84cm	14"/36cm	10"/25cm	24"/61cm	26"/66cm	77lb/35kg
6555.US	Blizzard Stretch, DEC3 Enclosure Control, 120V	41"/104cm	45"/114cm	16"/41cm	12"/30cm	35"/89cm	26"/66cm	97lb/44kg
6555.IN	Blizzard Stretch, DEC3 Enclosure Control, 230V	41"/104cm	45"/114cm	16"/41cm	12"/30cm	35"/89cm	26"/66cm	97lb/44kg
6556.US	Blizzard X-Stretch, DEC3 Enclosure Control, 120V	49"/124cm	51"/130cm	16"/41cm	12"/30cm	42"/107cm	26"/66cm	106lb/48kg
6556.IN	Blizzard X-Stretch, DEC3 Enclosure Control, 230V	49"/124cm	51"/130cm	16"/41cm	12"/30cm	42"/107cm	26"/66cm	106lb/48kg
6560.US	Blizzard, Force-cooled, 120V	31"/79cm	33"/84cm	14"/36cm	10"/25cm	24"/61cm	26"/66cm	67lb/30kg
6560.IN	Blizzard, Force-cooled, 230V	31"/79cm	33"/84cm	14"/36cm	10"/25cm	24"/61cm	26"/66cm	67lb/30kg
6565.US	Blizzard Stretch, Force-cooled, 120V	41"/104cm	45"/114cm	16"/41cm	12"/30cm	35"/89cm	26"/66cm	87lb/40kg
6565.IN	Blizzard Stretch, Force-cooled, 230V	41"/104cm	45"/114cm	16"/41cm	12"/30cm	35"/89cm	26"/66cm	87lb/40kg
6566.US	Blizzard X-Stretch, Force-cooled, 120V	49"/124cm	51"/130cm	16"/41cm	12"/30cm	42"/107cm	26"/66cm	96lb/47kg
6566.IN	Blizzard X-Stretch, Force-cooled, 230V	49"/124cm	51"/130cm	16"/41cm	12"/30cm	42"/107cm	26"/66cm	96lb/47kg

Maximum Projector Lamp Power – 1,300 Watts

2 Installation





2.1 Safety and Warnings

These warnings are for your protection. Failure to comply may result in serious injury or death. Tempest Lighting, Inc. assumes no responsibility for damages or injury incurred by misuse or mishandling of product.



-  **Do not** attempt to install or operate the enclosure before fully reading and understanding this manual
-  **Never** allow anyone who has not read this manual to open the enclosure or perform maintenance on the projector within.
-  **Never** leave the enclosure unattended when open.
-  **Always** make sure all bolts and latches are tight and safety locks are in place after performing any form of maintenance on the unit.
-  **Do not** open any electrical boxes until power has been shut off to all supply lines to the enclosure (including the one powering the projector).
-  **Do not** open the enclosure in wet weather.

2.2 Tools and Equipment

To install the enclosure, you will need the following items:

-  Crescent wrench
-  Phillips screwdriver
-  Terminal screwdriver
-  Proper wiring installation equipment (for line power and signal wiring)
-  Any equipment listed in the projector manufacturer's projector-specific installation directions

2.3 Mounting the Blizzard Enclosure

-  The Blizzard enclosure must be mounted on or under a solid structure rated for the weight of the enclosure, the projector inside it, and at least one person.
-  Snow - if installed outside in cold regions, the bottom of the Blizzard enclosure must be at least 2' (60cm) above maximum height of any snowfall or drifting snow, subject to local conditions. If snow is not a consideration, then enclosure may sit on the ground as long as proper drainage is provided.

- ❶ LEAVE ADEQUATE CLEARANCE BEHIND ENCLOSURE FOR WIRING AND VENTILATION
- ❶ *Tempest Lighting recommends the use of stainless steel mounting hardware.*

The Blizzard enclosure is provided with a pair of Unistrut channels on the enclosure base, for mounting to your structure. You may use standard Unistrut accessories, or purchase mounting kits from Tempest Lighting – four kits are required per enclosure.

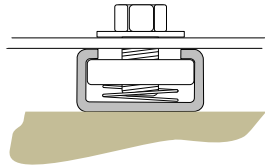

4900.MB *Stainless Steel Unistrut channel nut, bolt and washer. Four required per enclosure.*

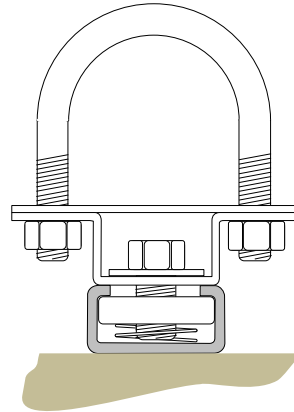

4900.MC *Stainless Steel Unistrut channel nut, bolt and pipe clamp, for pipes 1.5" (38mm) to 2" (50mm) OD. Four required per enclosure.*

4925.MC *Stainless Steel Unistrut channel nut, bolt and pipe clamp, for pipes 2" (50mm) to 2.5" (64mm) OD. Four required per enclosure.*

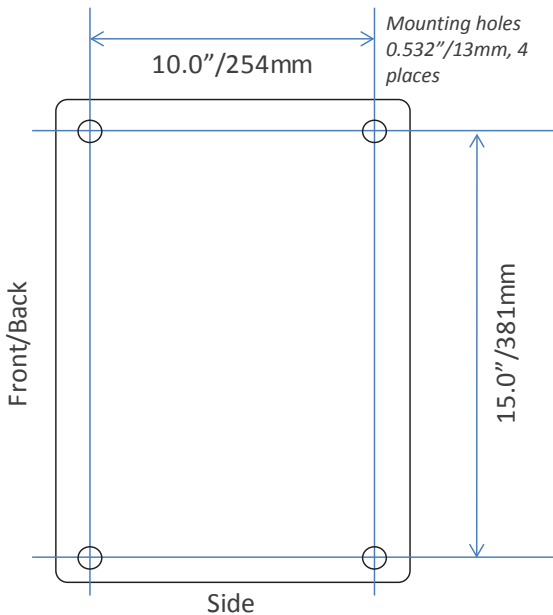

Suggested layout for mounting plate, using four 4900.MB kits.

2.4 Mounting Base-down and Base-up

All Blizzard enclosures are designed to be mounted base-down, on a solid structure, using Unistrut mounting hardware. They may also be suspended from an overhang, ceiling or truss, using the same hardware. Note that in this event it will be necessary to flip the projector image, since the projector itself will be hanging upside-down. It's important to be sure that the projector to be used supports this feature (usually referred to as Ceiling Mount mode) before commencing installation.

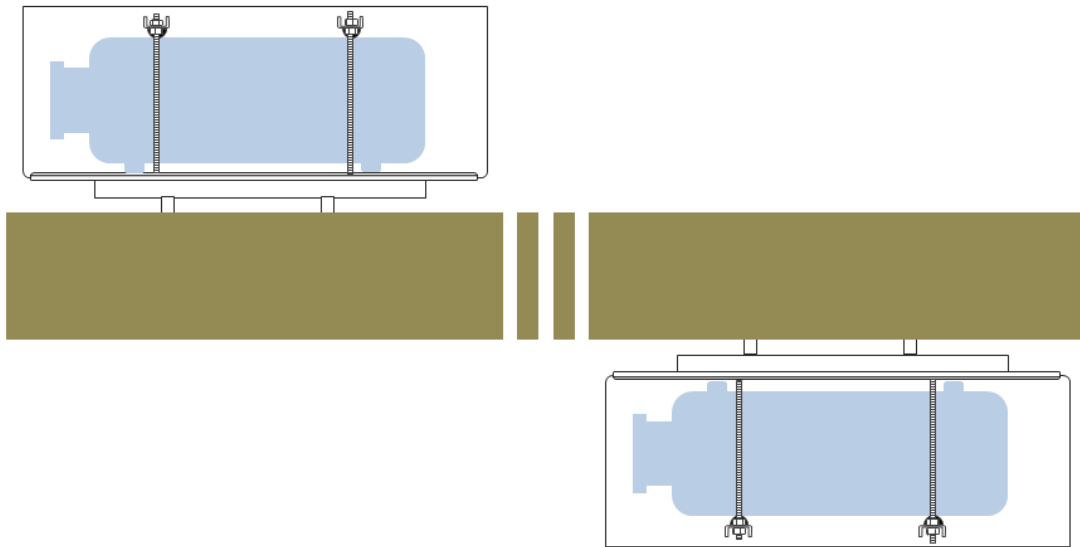

Air vents for Base-up operation

When the Blizzard is used base-up, remove the front and back air vents, invert, and replace, to prevent rainwater ingress.

Rear air exhaust vent, inverted for base-up operation. Do the same with the front intake vent.



IMPORTANT SAFETY NOTICE:

It is the responsibility of the installer to ensure that all mounting points are secure and conform to local safety regulations. Tempest Lighting Inc. accepts no responsibility for damage or injury arising from inappropriate or unsafe installation.

2.5 Mounting the Projector in the Blizzard Enclosure

⚠ If the Blizzard enclosure is suspended from a ceiling or overhang, this must be done by two people.

1. Find the best location for the two projector clamps, avoiding contact with access doors, vents and control on the projector top.
2. Make sure that all four Projector clamp threaded rods are screwed into the projector tray, and locked in place with the locknut provided.
3. Remove the projector clamp bars.
4. Place the projector on the projector tray. If hanging the projector upside-down, one person must hold the projector in position, while another person secures the projector clamp bars in place.
5. Replace the projector clamp bars, with the rubber pads pressing firmly onto the projector cover, and tight the nuts above and below each end of each projector clamp.
6. Ensure that the projector is securely held before proceeding further.

Note: You can still adjust the projector pan and tilt by loosening the projector clamp, adjusting the projector feet, then re-tightening the projector clamp to hold the projector firmly in place.

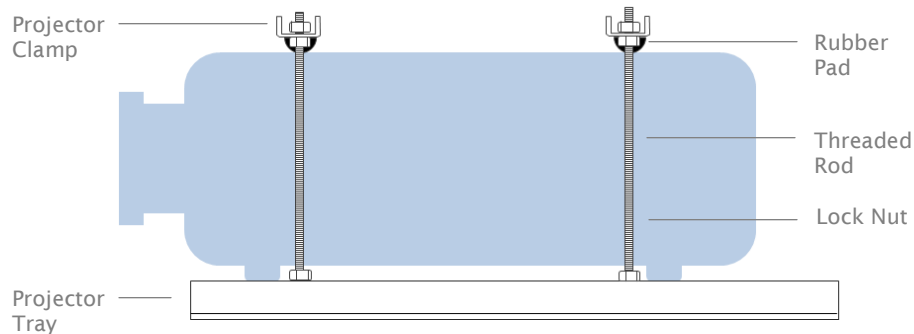

7. Connect the projector power cable to the projector, and plug into the receptacle provided inside the enclosure:

International Versions (.IN part # suffix) are equipped with CE17 16amp 2P+E receptacles

US Versions (.US part # suffix) are equipped with NEMA L6-20 receptacles

8. Connect projector signal cables
9. Tie down any cables away from the exhaust fan
10. Power up the projector, check functions and adjust focus
11. Replace the enclosure cover
12. Make sure that all latches are securely fastened. The latches are adjustable, and should be checked periodically, since the rubber seal may compress slightly over time.
13. For additional security, use a bolt or padlock to lock one or more of the latches, using the security ring provided.

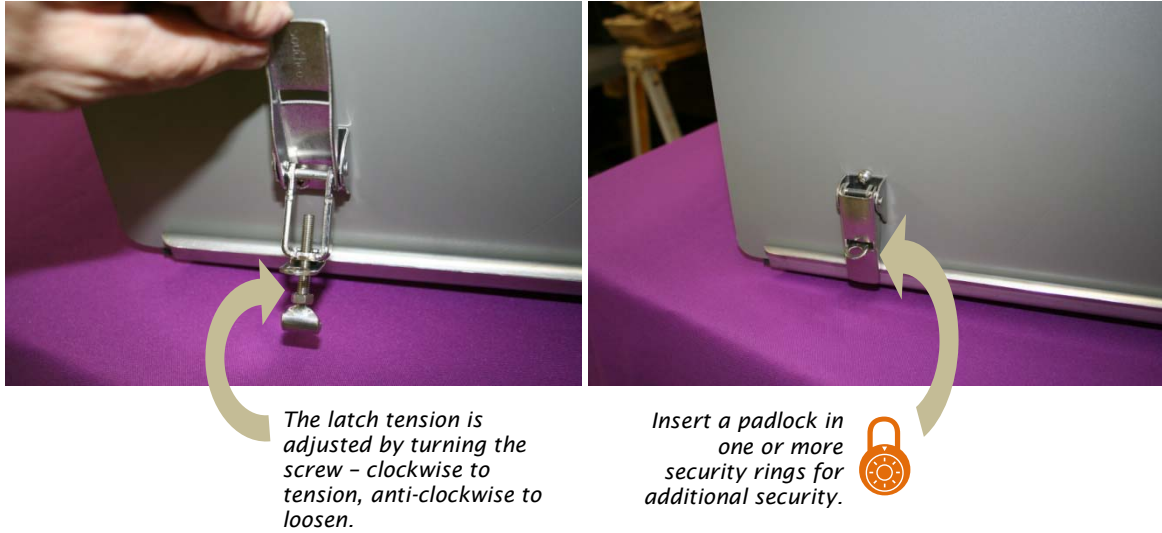

Installing the Blizzard Blimp Accessory

If you ordered a Blimp kit with your Blizzard, the installation is exactly the same, except that the fan is remote from the enclosure and needs to be installed separately.

The Blimp kit provided with your enclosure comprises additional sound insulation inside the enclosure, plus a remote fan kit.

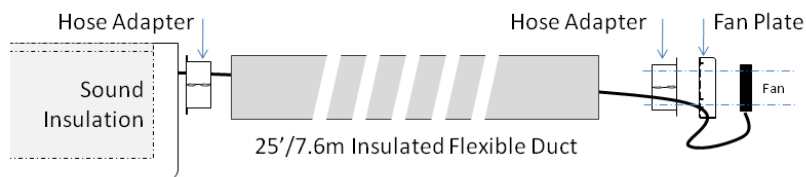

1. Attach a Hose adapter plate to the exhaust air location on the right side of the rear panel, using the four 8-32 screws provided
2. Thread the fan cable through the padded hose provided, using a fish tape
3. Pass the fan cable through the hose adapter, and connect to the FAN terminals inside the enclosure, passing the fan cable through the rubber grommet in the side of the electrical cover.
4. Attach one end of the hose to the hose adapter plate, using one of the clamps provided.
5. Attach the other end to the Fan assembly in the same way, taking care not to crimp the fan cable.
6. Feed the hose through the wall or ceiling to a suitable location and screw in place. This will normally be either in a large ceiling void, or in a remote location with access to outside air.
7. DO NOT EXTEND the hose beyond its 25'/7.6m length. It has been tested at this length, and extending it further may reduce cooling efficacy inside the enclosure.

3 Wiring

3.1 Electrical Preparation

⚡ **All electrical work must be carried out by a properly licensed electrician. Failure to observe this point will void the factory warranty for the Tempest Enclosure and possibly the projector/projector.**

- 1 Before starting work, switch off power to the branch circuit, carefully following lockout and tag-out procedures. Failure to do so could cause serious injury or death.
- 2 Two or three electrical junction boxes will be required within a short distance of the Blizzard enclosure for:
 - AC Supply wiring (Projector)
 - AC Supply Wiring (Enclosure Fan) – may be combined with projector power feed if desired
 - Projector picture signal wiring

3 Your Blizzard enclosure is supplied fitted with two cable entry points, suitable for flexible conduit fittings. US size ½”, international 20mm.

Note the locations of the cable entry fittings on the rear panel

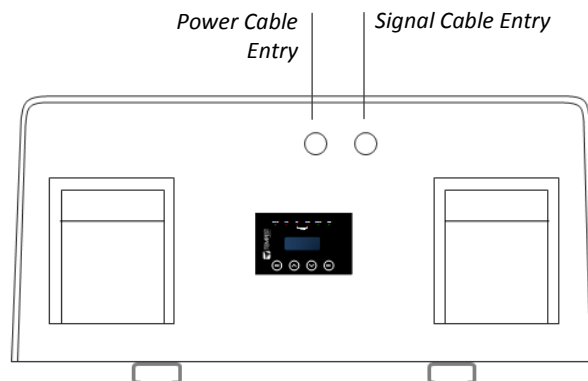

- 3 All junction boxes must be installed in accordance with local electrical codes and should be located near the permanent installation of the enclosure. Each junction box requires a length of flexible conduit, long enough to reach from junction box to the enclosure conduit fittings. Leave slack for positioning of enclosure, and enough space behind the enclosure for ventilation.
- 4 The AC supply must be protected by a fuse or circuit breaker of a rating suitable for the projector. For the DEC3 versions, add max 550W load for the enclosure fan and heater.
- 5 The user may connect the fan and the projector to the same switched supply, or run them separately, according to need. If run separately, it is the user’s responsibility to ensure that the fan is always running when the projector lamp is on.

3.2 Fan- Only Versions:

Remove the electrical cover inside the enclosure. You will see the fan wires already terminated to the connector block on the rear panel.

Pass the AC feeder wires through the rear panel and terminate to the connector block, using one of the wiring diagrams below.

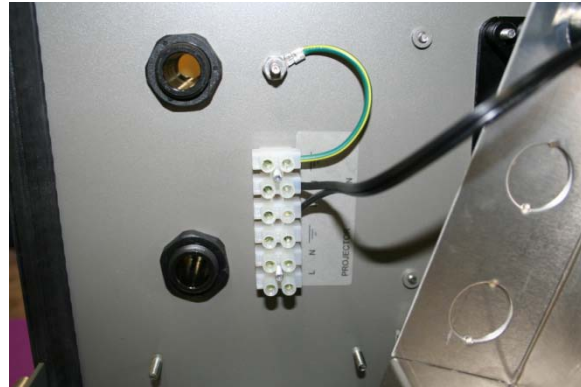

Feed the projector power cable through the grommited hole in the electrical cover, and terminate as shown in the wiring diagrams below.

Replace the electrical cover, taking care not to pinch any of the power wires.

Use the second cable entry to run projector signal and control cables to the projector, as specified by the projector manufacturer.

Wiring Diagrams

120V Dual Feed

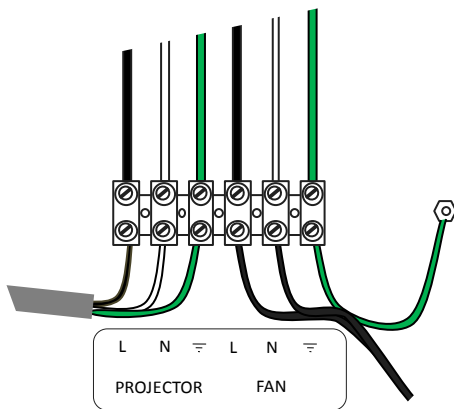

120V Single Feed

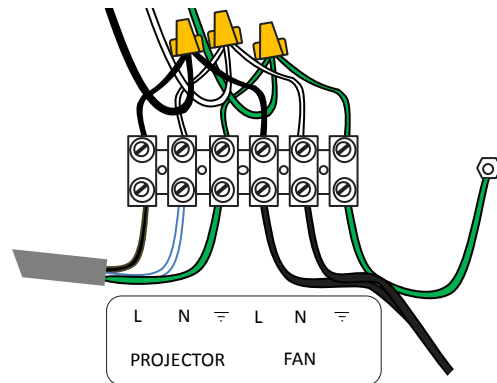

230V Dual Feed

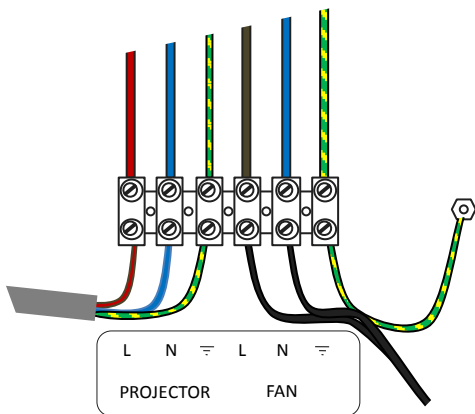

230V Single Feed

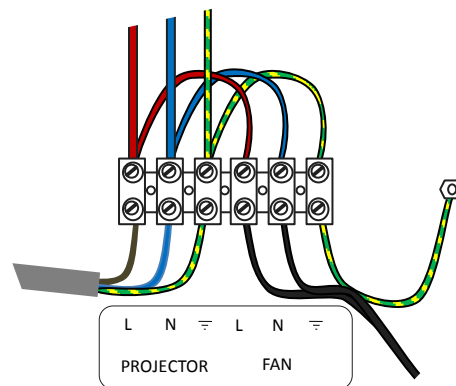

DEC3 normally ships from the factory with power terminal links inserted for a common electrical supply to feed the enclosure and the projector/fixture inside it.

If you prefer to feed the enclosure and projector separately, remove the terminal links as indicated before connecting to mains power. Use a small flat-bladed screwdriver to remove the link, snap off the unneeded section and replace carefully. When splitting the feeders, we strongly recommend feeding both supplies from the same phase and at the same supply voltage.

3.1 DMX Connections

DMX refers to USITT DMX512, a commonly used control protocol in the entertainment industry, running over RS485. Consult USITT DMX installation guidelines when laying out a system, or consult a qualified DMX system integrator.

Note that DMX is optional - in many applications it is not required, and need not be connected. For more information, see DEC3 Operating Modes in the next section.

DMX IN - Connect incoming DMX to the 2-part 3-pin terminal on the DEC3 control circuit board so labeled.

Pinout: (1) Ground, (2) Data -, (3) Data +.

DMX THRU - there are two DMX pass-through terminals - one for a fixture inside the enclosure, the other to run to the next DMX device in the network.

Pinout: (1) Ground, (2) Data -, (3) Data +.

DEC3 Control – Introduction

Tempest Lighting and Projector Enclosures have been in daily use around the world for almost a decade. Tempest enclosures protect expensive and delicate equipment in all climates, maintaining a comfortable operating temperature, and preventing condensation – the real outdoor enemy.

DEC3™ – that’s *Digital Enclosure Control, third Generation* – is the brain of your Tempest enclosure. It will maintain the internal environment in a comfortable temperature and humidity range, and prevent condensation – the real equipment killer. DEC3 monitors internal temperature, humidity and lamp current at all times, and uses this information to control its lamp relay, fan(s) and heater(s). It can report back over the DMX cable, using the RDM protocol (Remote Device Management) if desired.

Unless otherwise specified, this version of the user guide refers to DEC3 units fitted with software version 2.1 or later.

So, what does DEC3 actually DO?

DEC3 is the brains of the operation – here’s a layout:

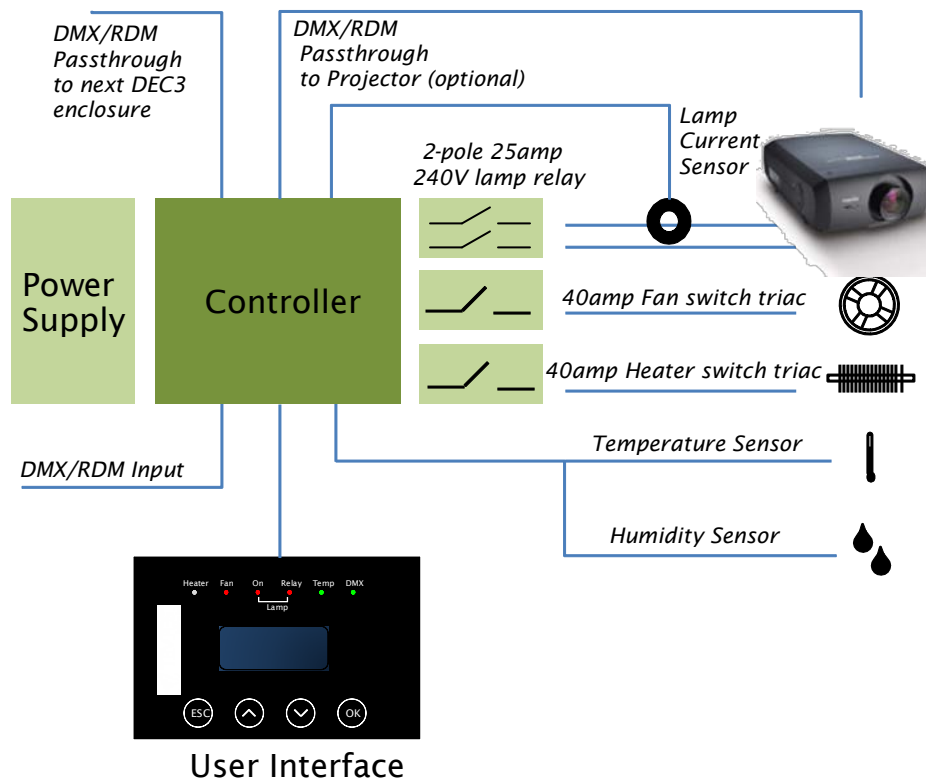

This schematic shows the relationship between DEC3’s functional elements. The power supply is universal 90-260V, but fans and heaters are either 120V or 230VAC, and must be so specified. A high-quality 25amp 2-pole electro-mechanical relay isolates fixture/projector power in the event of an over-temperature condition. Fans and heaters are switched using generously overrated 40amp Triac devices for maximum reliability. Two DMX outputs connect to the internal fixture (if desired) and on to other enclosures or DMX devices.

DEC3’s mission is to maintain temperature and humidity inside the enclosure, within determined bounds, and to prevent condensation – particularly overnight dew formation – inside the equipment housed. Condensation is fatal to electronic equipment, particularly in polluted areas or saline environments, where it brings not only rust and short-circuits, but also a steady buildup of mineral and/or salt deposits. Incidentally, condensation is very hard to control with air-conditioning type systems, which is why we don’t use them.

Broadly speaking, DEC3’s function depends on whether the fixture/projector lamp is on or off:

Lamp ON

When the projector/fixture is running, the heat from the lamp takes care of humidity, and DEC3 runs the enclosure's fan(s) to change its air every few seconds - ensuring minimal temperature rise above outside ambient.

Lamp OFF

When the lamp is off, DEC3 senses temperature and humidity and controls its fan(s) and heater(s) accordingly. When conditions are within normal bounds (between top and bottom temperature settings and below the humidity threshold (see below), DEC3 pulses the heater at a low level to dry the air and eliminate condensation, and runs the fans to change the enclosure air every 30 seconds or so. We call this 'pulse mode', and it is the key to preventing damaging condensation inside your equipment.

If the temperature rises above the top set limit (see below), DEC3 runs the fans to cool it down. In cold conditions, DEC3 will run the heater as required to maintain the bottom set temperature.

Thus, DEC3 maintains a comfortable operating temperature inside the enclosure, and prevents damage from condensation. Users all over the world have found that Tempest enclosures provide an optimal environment for expensive and delicate equipment, in every climate type.

And while doing all of this, DEC3 can tell you what's happening over your RDM network - a real boon in larger installations.

Operating Modes

DEC3 may be run in one of three basic operating configurations. A fourth configuration is provided for test and service use.

Standalone: The enclosure operates independently, and automatically, requiring no user intervention. User may set parameters such as temperature and humidity thresholds, and monitor sensor information and DEC status at the DEC3 user interface. Standalone is the default DEC3 shipping mode unless specified otherwise at time of order. DMX is not required or utilized.

DMX/RDM Mode 1 (RDM Monitor)

All of the Standalone features plus the ability to discover and monitor the DEC3 over a DMX512 connection, using RDM.

In this mode, the DEC3 does not need to “see” any DMX to operate. The mode allows the use of RDM to set the various temperature thresholds, and monitor the conditions inside the enclosure remotely. The fixture inside the Tempest enclosure may also be an RDM enabled device.

DMX/RDM Mode 2 (DMX Enable)

All of the Standalone and RDM Monitor features plus the use of a single DMX address (slot) to control the Lamp Relay.

This means that the user is responsible for maintaining a DMX input with the slot (as selected as the DMX START ADDRESS on the DEC3) high. This slot level must be set greater than 50% at all times when the internal fixture is to be powered. This has the useful attribute of enabling the user to remotely force a hard reset of the fixture by opening and then closing the Lamp Relay. It also means that it is unnecessary to feed the enclosure with two power sources (for the enclosure and the luminaire/projector), since the DMX slot may be used to isolate the projector when not in use, without removing power from the enclosure. This mode is recommended for show-control applications, where it is desirable to have power control of the internal fixture, and accidental loss of the DMX data is very unlikely to occur.

In the absence of DMX, the Lamp Relay defaults to “ON”.

All RDM functions are available for configuration and monitoring of the DEC3.

DMX/RDM Mode 3 (Service/Test)

This mode is intended for test and service use.

It gives the user direct control of the lamp, fan and heater relays over DMX. User may NOT override any of the relays in an unsafe direction – for example, if the DEC3 has determined the enclosure is over-temperature and has switched off the lamp relay, the relay may not be overridden ON by DMX. In this sense, DMX ‘piles

on' to DEC3 operation, within defined safety limits. However, until such time as the temperature reaches the TOP limit, the heater may be enabled and the fan disabled, which is why the mode should only be used for Test and Service use.

If the DEC3 has been purchased with DMX/RDM enabled, it is possible to select the required mode 1-3 using RDM. In the RDM context, this is known as selecting the device's DMX PERSONALITY. Setup of the DEC3 from the Front Panel is available in all configurations.



RDM is an effective and powerful tool for commissioning and monitoring an installation, particularly in large systems. For further guidance, we recommend you consult a qualified RDM system integrator. If you don't have one in your neighborhood, go to www.tempestlighting.com, and click on the RDM and RDM Integration bug on the home page for some useful contacts. Tempest Lighting warrants DEC3 to be compliant with the RDM standard, but is not an RDM systems integrator, and can offer only basic guidance on RDM utilization.

DEC3 Control Parameters

DEC3 will run out of the box with its default parameter settings, which equate to the (fixed) settings of its predecessor DEC's 1 and 2.

Temperature:

Top Set	<p><i>Range 35-45°C, Default = 40°C</i></p> <p>Most manufacturers recommend a max temperature for their equipment of 40°C, though this does vary. When DEC3 senses a temperature higher than Top Set, it indicates an overtemp condition as a warning. NOTE: in moving light enclosures the thermal sensor is necessarily placed in the exhaust air path, which will be higher (sometimes a lot higher) than the actual fixture ambient. This needs to be kept in mind when adjusting temperature settings.</p>
Cutoff Temp	<p><i>Range 0-15°C, Default = 15°C</i></p> <p>This is a setting <i>above</i> the Top Set temperature that determines the temperature at which the lamp relay is opened, cutting off power from the fixture/projector. The user may reduce it as desired, but should establish before doing so the actual operating temperatures experienced in hot weather before doing so, to avoid nuisance tripping.</p>
Bottom Set	<p><i>Range 0-10°C, Default = 10°C</i></p> <p>The temperature maintained by the heater in cold conditions. Most equipment manufacturers recommend a minimum</p>

operating temperature of 0°C, and users may set it lower than the default if desired.

- Humidity Range 50-90%, *Default 80%*
The threshold at which incoming air is more aggressively heated to remove moisture. This parameter will not normally require adjustment.
- DMX Set *Range 001-510, Default 001*
Sets the DMX address for the lamp relay control. In the DMX/RDM service mode, the subsequent two DMX slots control fan and heater respectively.
- Lamp Hours *Default 0000*
DEC3 counts the hours your projector/fixture lamp is on, and can report it both on the user interface display and over RDM. ***Remember to reset to 0 when changing lamps.*** This is provided to allow lamp hours monitoring on devices such as Video Projectors and certain moving lights that have no native RDM or DMX support.

Setup and Connections

Operating Mode Setup

Your DEC3 will normally be factory set to the operating mode you specified in your order:

Operating Mode DIP Switch Settings

Mode	DIPswitch Settings	Mode Summary
Standalone	1-6 OFF	Standalone – no DMX/RDM
DMX/RDM	2 ON, 1, 3-6 OFF	DMX/RDM Modes 1-3 – support for remote monitoring

DMX Connections

DMX refers to USITT DMX512, a commonly used control protocol in the entertainment industry, running over RS485. Consult USITT DMX installation guidelines when laying out a system, or employ a qualified DMX system integrator.

Note that DMX is optional – in many applications it is not required, and need not be connected.

DMX IN – Connect incoming DMX to the 2-part 3-pin terminal on the DEC3 control circuit board so labeled.

Pinout: (1) Ground, (2) Data -, (3) Data +.

DMX THRU – there are two DMX pass-through terminals – one for a fixture inside the enclosure, the other to run to the next DMX device in the network. Pinout: same as DMX IN.

DMX Line Terminations

DMX cable runs must be terminated at the far end of the cable run with a termination resistor as detailed in the DMX standard. This is particularly important for satisfactory operation of DMX/RDM installations. The individual fixtures installed inside the Tempest enclosures must NOT be terminated. It is recommended that any line termination is done using the 3-pin terminal connector fitted to the DEC3 control circuit board.

1. Make sure that any DMX termination provided by the fixture inside your enclosure(s) is disabled.
2. The LAST enclosure in the installed DMX daisy chain should have a DMX Termination fitted to one of the pass through DMX connectors. Per the ANSI E1.11 standard, the Terminator shall be 120 ohm +5%/-10% impedance placed between Data+ and Data-. We recommend minimum power rating of 0.6W for the resistor.
We recommend that the installer fit a label externally to say “DMX Termination fitted internally”.

Test:

3. Switch mains power OFF to all enclosures.
4. Before connecting the DMX line to your controller, measure the impedance between Pin 2 (Data-) and Pin 3(Data+) at the controller end. Reading should be around 100-130 ohms.

This test shows that you have a terminator in place, and also that you have continuity of Data- and Data+ between installed devices. If the measured resistance is significantly less than 100 ohms, (say 40-80 ohms) it suggests you may have multiple terminations in place. Check that any terminator switches on light fixtures are OFF. If impedance is very low, check for wiring shorts.

RDM Connections

RDM refers to ANSI E1.20, a control protocol in the entertainment industry gaining popularity and essentially an “extension” of DMX512. The use of RDM is optional – but it does require a DMX512 cable connection.

Important – RDM and RDM Integration

RDM (Remote Device Management) is an ANSI standard that adds bidirectional discovery and status monitoring to a standard DMX network connection. No additional wiring is required for RDM operation.

DEC3’s RDM implementation allows system integrators to set up remote control and status monitoring of all attributes and sensors, including:

- Temperature
- Humidity
- Lamp Current
- Elapsed Lamp Hours
- Lamp Relay Status
- Fan Relay Status
- Heater Relay Status
- DMX Status
- DMX Start Address
- DMX Personality (RDM Mode)
- Device Type
- Device Label
- Software Version

Tempest Lighting warrants that its RDM products are compliant to the RDM standard, but does not directly support RDM system integration. Tempest Lighting will however provide introductions to qualified RDM system integrators for customers requiring assistance in this area. Links are provided on the Tempest Lighting web site (www.tempestlighting.com).

Control Interface

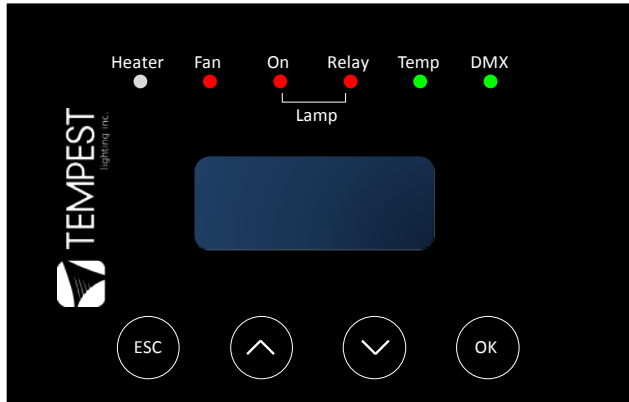

The control interface features a 2-line display, LED indicators, and 4 cap-sense control buttons.

LED Indicators

Heater

SHORT PULSE (RED) - Indicates lamp is off, and the heater is pulsing to prevent condensation inside the enclosure and projector/light fixture. This is normal operation when the lamp is off and the temperature range is above the bottom set limit.

ON (RED) - Indicates heater is on, due to temperature being below bottom temperature setting when lamp is off.

OFF - indicates lamp is on and maintaining temperature above bottom limit.

Fan

SHORT PULSE (RED) - The fan is moving a little air through the enclosure, as part of the condensation prevention strategy. The fan comes on for a few seconds approximately every 30 seconds.

ON (RED) - Indicates fan is running, due to lamp being on or internal temperature exceeding top limit.

Lamp Relay

ON (RED) Indicates lamp relay closed and power is available to the internal fixture/projector.

OFF Indicates lamp relay open and power is removed from the internal fixture.

Lamp On

ON (RED) Indicates current sensed on the lamp circuit greater than 1 amp (this allows some current to be drawn for such things as fans and control electronics without the Lamp On indicator lighting. When the Lamp On indicator is on, the lamp counter is counting lamp life.

Temp

ON (GREEN) - The temperature is between Bottom and Top temperature settings.

FLASHING (RED) - The temperature is above Top setting but has not yet reached the Cutoff level.

ON (RED) - Temperature is above Cutoff level or below Bottom level.

DMX (only used when DMX/RDM setting is in effect)

ON (RED) - DMX error.

ON (GREEN) – Good DMX or RDM data packet received.

Control Interface Operation

The Control Interface is normally LOCKED.

To UNLOCK, touch ESC and OK together for 5 seconds.

You are now in the CONTROL MENU

Use the arrow keys to scroll up and down the menu.

Use OK, to enter a menu item, then the arrow keys to set the item parameter, or to scroll to the next menu level.

Use ESC to back up a level, and OK to confirm settings.

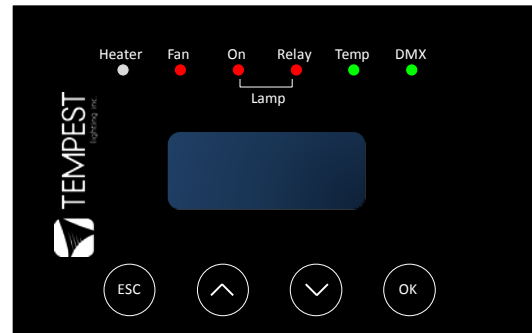

Depending on the Operating Mode selected, and present status, DEC3's display shows you temperature, humidity, DMX address and a selection of error and status messages.

CONTROL MENU

DMX SET (if DMX/RDM mode 2 or 3 is selected)

Select a DMX starting address in the range 001 to 510

1 – Lamp Relay

In RDM Mode 3 an addition two slots are required

2 – Fan Relay

3 – Heater Relay

Note that the DMX control is designed using a SAFETY pile-on Logic. In other words, the DMX input can only override automatic settings in a safe manner. For example, if the enclosure has switched off the lamp relay due to an over-temperature condition, the DMX input cannot switch it on, if the fans are running because of Overtemp, the DMX input cannot turn them off, and so on.

The DMX SET menu can be ignored if the DEC3 is in Standalone or DMX/RDM Mode 1 (RDM Monitor) mode.

SET LAMP HOURS TO 0

The lamp hour counter needs to be reset each time you change the lamp in the fixture/projector. Make this a part of your maintenance instructions.

STATUS DISPLAY

View Temperature (in Celsius) and Relative Humidity (in %) inside the enclosure. Note that in Tornado moving light enclosures the temp/humidity sensor is located in the exhaust airflow, which may be significantly warmer than ambient.

HUMIDITY SET

The humidity level above which the heater kicks in to remove humidity from incoming air (default 80%, permissible range 50-90%). This setting should not normally be changed.

TEMP SET

Set three temperature trigger points for Top, Cutoff and Bottom temperatures.

TOP TEMP

The desired upper temperature limit for normal operation (default 40°C, permissible range 35-45°C).

When the DEC3 sees air above this temperature, but below the additional Cutoff temperature (see below), it indicates a temperature error. This is not dangerous, but may reduce lamp life.

CUTOFF TEMP

The desired upper temperature ABOVE the TOP TEMP setting, at which the lamp relay is forced to open, isolating the fixture/projector power.

(default 15°C, permissible range 0-15°C).

To avoid nuisance tripping, set this variable to the maximum, and monitor actual temperatures in your normal operating conditions. If your actual temperatures are running lower, then you may reduce the cutoff temperature margin. In hot climates, it may be advisable to set both TOP TEMP and CUTOFF TEMP as high as possible.

BOTTOM TEMP

The desired lower temperature limit for normal operation

(default 10°C, permissible range 0-10°C).

Note that a higher BOTTOM TEMP may provide additional protection against condensation in some conditions, but will consume more energy. Therefore a lower setting is desirable, provided the user is certain that no condensation is occurring.

RDM MODE SET

The RDM Mode is normally set using RDM commands from a remote RDM control device to set the DMX PERSONALITY of the DEC3.

From the DEC3 user interface, this menu item allows the user to check (and if necessary alter) the RDM mode. Please ensure that the DEC3 is NOT unintentionally left in Mode3 (Service/Test).

5 *Operation – Fan- Only Versions*

While there are no specific operational actions required for normal use, the following points should be kept in mind.

- ① **IF the fan and projector have been powered separately, it is the responsibility of the user to ensure that the fan is running at all times when the projector lamp is on.**
- ① Unless the enclosure or projector is undergoing routine maintenance, the enclosure should be closed and securely latched at all times.
- ① Only authorized personnel should open the enclosure (see maintenance warnings in the next chapter).
- ① **Do not routinely operate projector in full sun in hot weather. The enclosure has not been designed to protect the projector in this condition.**





6 Routine Maintenance

It is very important to perform routine maintenance on both the enclosure and the projector inside it. Failure to do so may reduce lifetime for both the enclosure and the projector.

Note

Maintenance schedules depend on location and environment. The intervals given here are general minimum guidelines. It is up to the user to judge whether maintenance should be carried out more frequently. We recommend doing these tasks no less often than mentioned here.

Safety

-  As the enclosure is a powered unit with moving parts, it is necessary to keep safety in mind while performing routine maintenance. Although maintenance can be performed while the enclosure is powered, it is safer to carry it out with the power disconnected with proper lockout and tag out procedures followed.
-  Be aware that once the enclosure has had power applied to it, the fan will start to turn. Make sure that your hands are clear of the fan before applying power to the enclosure.
-  Only authorized personnel should perform maintenance on the enclosure or projector
-  Do not service the unit in the rain or other adverse weather conditions (snow, sleet, high winds, etc.).

Inspection Checklist: - Every Three (3) Months

- Glass should be clean and free of cracks
- Enclosure should be free of debris both inside and out
- Bolts and tie-down straps should be tight
- Door seals should be in good condition. Check seals inside and out for gaps.
- Fan should be functioning and not making excessive noise
- Intake filter should be clean

Air Filter - Every Three (3) Months

The air filter from the intake vent on front of enclosure (back on 6550/6650) should be removed and cleaned on a regular basis. To remove filter, pull it directly out of the intake vent. The filter can be cleaned by running water from a hose and do not require any special solution.

To reinstall, push filter back into Velcro on the bottom of the intake vent. Filter should be flush with bottom of vent.



Case - As Needed

The outside of the case should be cleaned as needed. The case should be cleaned with a wet cloth and mild detergent (if necessary). Do not use a direct spray from a hose to clean the case.

Window - As Needed

Clean using a proprietary glass cleaning solution or a mild detergent, and wipe dry. Use only soft, lint-free cloths for glass cleaning. Never use an abrasive cleaner.

Projector

Review the manufacturer's instructions for proper maintenance of your projector/projector. Remember, the enclosure simply protects the equipment inside it and is not a substitute for regular maintenance.

7 Troubleshooting

This is a guide to the general symptoms, problems, and solutions that may occur during the usage of your enclosure. However, it is important to remember that problems may occur within the projector itself and these must also be considered.

Projector does not have power.

Check power supply wiring and voltage.

Fan is not spinning

Fan cords may have become disconnected. Check connections between fan and cord.

Fan may be obstructed. Shut off power to enclosure and check for obstructions. Turn power back on to see if fan will start spinning. If fan does not turn then enclosure is not receiving power.

Turn off all power and check wiring. If the wiring is correct, contact technical support.

Projector does not have power.

Check projector power switch. If switch is on, check wiring and supply switch/circuit breaker.

Projector turns on and off repeatedly over short span of time.

Check that vent areas and airways are clear. If so, ambient temperature may be too high, or projector may have internal problem.

Excessive water in enclosure.

Glass seal leak. Repair with silicone sealant.

Door gaskets leak caused by separation. Silicone piece back into place or replace section.

8 Limited Warranty

What is covered. Exclusions.

Unless otherwise stated, your product is covered by a one (1) year parts and labor limited warranty. Factory-painted product is not guaranteed against scratches. It is the Owner's responsibility to furnish receipts or invoices for verification of purchase date, and dealer or distributor. If purchase date cannot be provided, date of manufacture will be used to determine start of warranty period. Unless otherwise specifically stated in writing, all warranty work is carried out at the Tempest Lighting factory. In the event that the Owner purchases any optionally available on-site check-out or turn-on services, Owner agrees to provide facilities to perform such services at ground level. Tempest Lighting does not in any way offer any warranty for the projector.

Owner Responsibility for Installation.

Tempest Lighting makes no recommendations for mounting any Tempest Lighting product. It is the sole responsibility of the Owner to perform any necessary structural, electrical, environmental or other appropriate analysis prior to installing any Tempest Lighting product.

Returning an Item Under Warranty for Repair.

It is necessary to obtain a Return Material Authorization number (RMA#) from your dealer or point of purchase, BEFORE any units are returned for repair. The manufacturer will make the final determination as to whether or not the unit is covered by warranty.

Any Product unit or parts returned to Tempest Lighting, Inc., must be packaged in a suitable manner to ensure the protection of such Product unit or parts, and such package shall be clearly and prominently marked to indicate that the package contains returned Product units or parts and with a Return Material Authorization (RMA#) number. Accompany all returned Product units or parts with a written explanation of the problem or malfunction.

NOTE: *Freight Damage Claims are invalid for projectors shipped in non-factory boxes and packing materials. These materials can be supplied if requested, at additional cost. It is recommended that all packaging material be retained for possible re-use.*

Freight.

All shipping charges must be prepaid by the Owner. Items under warranty shall have return shipping paid by the manufacturer only in the Continental United States. Under no circumstances will freight collect shipments be accepted. Prepaid return shipping does not include expediting such as airfreight. Airfreight will ship customer collect.

REPAIR OR REPLACEMENT AS PROVIDED FOR UNDER THIS WARRANTY IS THE EXCLUSIVE REMEDY OF THE CONSUMER. TEMPEST LIGHTING, INC. MAKES NO WARRANTIES, EXPRESS OR IMPLIED, WITH RESPECT TO ANY PRODUCT, AND TEMPEST LIGHTING SPECIFICALLY DISCLAIMS ANY WARRANTY OF MERCHANTABILITY OR FITNESS FOR A PARTICULAR PURPOSE. TEMPEST LIGHTING SHALL NOT BE LIABLE FOR ANY INDIRECT, INCIDENTAL OR CONSEQUENTIAL DAMAGE, INCLUDING LOST PROFITS, SUSTAINED OR INCURRED IN CONNECTION WITH ANY PRODUCT OR CAUSED BY PRODUCT DEFECTS OR THE PARTIAL OR TOTAL FAILURE OF ANY PRODUCT REGARDLESS OF THE FORM OF ACTION, WHETHER IN CONTRACT, TORT (INCLUDING NEGLIGENCE), STRICT LIABILITY OR OTHERWISE, AND WHETHER OR NOT SUCH DAMAGES WERE FORESEEN OF UNFORESEEN.

Warranty is void if the product is misused, damage, modified in any way, or where unauthorized repairs or parts have been employed. This warranty gives you specific legal rights, and you may also have other rights, which vary from state to state.

Tempest Product Support.

Step 1: First contact your local Dealer for support. Your dealer is best placed to respond quickly to your needs.

Step 2: If your dealer is unable to answer your questions please contact our Sales Office:

Tempest Lighting, Inc.
13110 Saticoy Street
North Hollywood, CA 91605, USA
Tel +1 818 787 8984
Fax +1 818 982 5582
support@tempestlighting.com

Visit our web site for current information and specifications:

www.tempestlighting.com

9 *Registration*

Filling out the registration form on the next page and sending it to the Tempest Lighting factory within 30 days of installation entitles you to the warranty cover specified in this manual. It also enables us to notify you in case of important news or post-sale information regarding the Blizzard Lighting Enclosure.

Blizzard Enclosure Registration Form

Detach and mail/fax to:

Tempest Lighting, Inc., 13110 Saticoy St., N Hollywood, CA 91605

Fax # +1 818 982 5582

If a Tempest Representative has not inspected the installation, please send photos showing installation.

Model Number:

Serial Number:

Padlock Key Number:

Dealer/Sold By

Name:

Location:

Date Purchased:

Contractor/Installed By

Name:

Date Installed:

Location Installed:

Company/Organization

Name:

Street Address:
.....

City, State, ZIP, Country:
.....

Phone:

Fax:

Contact Information

Name:

Phone: Extension:

Fax:

E-mail: