

User Manual and Installation Guide



*Hurricane 1000 Series Enclosures,
DEC3 rev 2.1 and up*



September, 2010



You can download a copy of this manual at
<http://www.tempestlighting.com/products.html#Hurricane>

Tempest Lighting, Inc.
13110 Saticoy Street, Unit # C
N. Hollywood, CA 91605, USA

Tel +1 818 787- 8984
Fax +1 818 982- 5582
info@tempestlighting.com

In the interest of continuous product improvement, the information in this document is subject to change without notice. Neither Tempest Lighting, Inc. nor its representatives or agents may be held liable for expense or injury arising from it.

© Tempest Lighting Inc. All Rights Reserved



Declaration of Conformity

This is to certify that the following product:

1000.IN Hurricane 1000 Enclosure, 230V

is in Compliance with the following standards or specifications according to the EMC Directive 89/336/EEC.

EN55015, EN61000-3-4, EN61000-3-5, EN61000-4-2, EN61000-4-3, EN61000-4-4, pr EN61000-4-5, EN61000-4-6, EN61000-4-8, EN61000-4-11

and is in compliance with the following standards or specifications according to the Low Voltage Directive 73/23/EEC.

EN60598-1

This declaration is made by the manufacturer

**Tempest Lighting, Inc.
13110 Saticoy Street, Unit C**

North Hollywood, USA

This declaration is based on tests that were conducted on the submitted samples of the above mentioned products. Detailed results can be referred to test reports CET.TE200909 and LVT.Te200909.

Dated: March 24th, 2010

Signature 

Tempest Lighting Inc



Tempest Lighting, Inc.,

13110 Saticoy Street, Unit C, North Hollywood, CA 91605, USA

www.tempestlighting.com info@tempestlighting.com

t: +1 818 787 8984

f: +1 818 982 5582

Table of Contents

Topic	Section
Introduction.....	1
INSTALLATION.....	2
Safety and Warnings.....	2.1
Mounting the Enclosure.....	2.2
Orientation.....	2.3
Drainage Holes.....	2.4
Dimensions and Layout.....	2.5
Wiring.....	3
Electrical Preparation.....	3.1
Digital Enclosure Control.....	3.2
AC Connections.....	3.3
DEC3 Control.....	4
Operating Modes.....	4.1
DEC3 Control Parameters.....	4.2
Operating Mode Setup.....	4.3
DMX Connections.....	4.4
DMX Line Termination.....	4.5
RDM Connections.....	4.6
RDM Integration.....	4.7
Control Interface.....	4.8
Control Interface Operation.....	4.9
Mounting the Projector.....	5
Activation and Checkout.....	6
Operation.....	7
Routine Maintenance.....	8
Troubleshooting.....	9
Sample Specification Boilerplate.....	10
Warranty.....	11
Support.....	12
Registration.....	13

1 Introduction

The Hurricane™ Scanner Enclosure

Thank you for purchasing the Hurricane Lighting Scanner enclosure. Although originally intended for outdoor environments, the design of the Hurricane is such that it can satisfy many other needs. Not only will it protect against hostile outdoor conditions, but also against particulate, smoke, and other indoor conditions that can shorten the life of your high-output Lighting Scanner.

Using This Manual

This manual covers all Hurricane Models in the 1000 product series. Please read it in its entirety before starting work. All the information contained is important, and should be read carefully before proceeding. Heed all warnings and advisories.









Icon Key:

- ① Valuable information
- ⚡ Electrical Warning
- ⚠ Safety Information

2 Installation





2.1 Safety and Warnings

These warnings are for your protection. Failure to comply may result in serious injury or death. Manufacturer assumes no responsibility for damages or injury incurred by misuse or mishandling of product.

-  **Do not** attempt to install or operate the enclosure before fully reading and understanding this manual
-  **This enclosure is HEAVY – do not attempt to lift with fewer than two people.**
-  **Never** allow anyone who has not read this manual to open the enclosure or perform maintenance on the luminaire within.
-  **Never** leave the enclosure unattended when open.
-  Even after power has been disconnected from the enclosure, the internal heater may remain warm. Do not touch it unless you can be sure that the power has been off for at least one hour.
-  **Always** make sure all bolts are tight and safety cables are in place after performing any form of maintenance on the unit.
-  **Observe** all posted warnings in the enclosure itself.
-  **Do not** open any electrical boxes until power has been shut off to all supply lines to the enclosure (including the one powering the projector).
-  **Do not** open the enclosure in wet weather.

Tools and Equipment

To install the enclosure, you will need the following items:

-  Crescent wrench
-  Phillips screwdriver
-  Proper wiring installation equipment (for line power and DMX)
-  Any equipment listed in the fixture manufacturer's fixture-specific installation directions

2.2 Mounting the Hurricane Enclosure

- ① The Hurricane enclosure may be mounted horizontally or vertically, on a solid structure, truss or equivalent, rated for the weight of the enclosure and any equipment housed inside it.
- ① Snow - if installed outside in cold regions, the lowest part of the Hurricane enclosure must be at least 2' (60cm) above maximum height of any snowfall or drifting snow, subject to local conditions. If snow is not a consideration, then the enclosure must be installed at least 12"/30cm above ground level and maintained clear of drifting leaves and other potential blockages to good drainage.
- ① Enclosure will need to be powered at all times, although projector may not be.
- ① LEAVE ADEQUATE CLEARANCE AROUND ENCLOSURE TO OPEN TOP COVER FOR SERVICE
- ① *Tempest Lighting recommends the use of stainless steel mounting hardware.*

The Hurricane enclosure is provided with a pair of Unistrut channels under the enclosure base, for mounting to your structure. You may use standard Unistrut accessories, or purchase either of the mounting kits available from Tempest Lighting - four kits are required per enclosure.

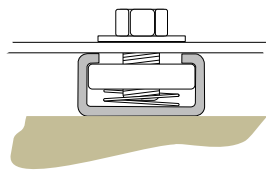

4900.MB *Stainless Steel Unistrut channel nut, bolt and washer. Four required per enclosure.*

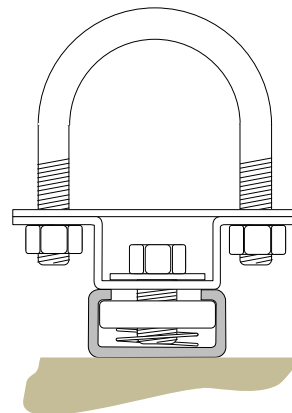

4900.MC *Stainless Steel Unistrut channel nut, bolt and pipe clamp, for pipes 1.5" (38mm) to 2" (50mm) OD. Four required per enclosure.*

4925.MC *Stainless Steel Unistrut channel nut, bolt and pipe clamp, for pipes 2" (50mm) to 2.5" (64mm) OD. Four required per enclosure.*

2.3 IMPORTANT: Orientation

Hurricane Enclosures may be mounted in the any orientation, subject to any limitations stipulated by the manufacturer of the projector housed inside it. You are advised to check the projector manufacturer's installation manually carefully before planning your installation.

2.4 IMPORTANT: Drainage Holes

When the enclosure is installed, drill two 1/4" (6mm) holes at the lowest point in the enclosure, to allow any water inside the enclosure to drain away. If the enclosure is mounted vertically, drill two holes in the bottom of the lower fiberglass cowl.

The NEMA 3R standard to which the enclosure is designed allows some water ingress, provided there is a drainage path for the water to escape. Small amounts of water will not cause any damage, provided they can drain away.

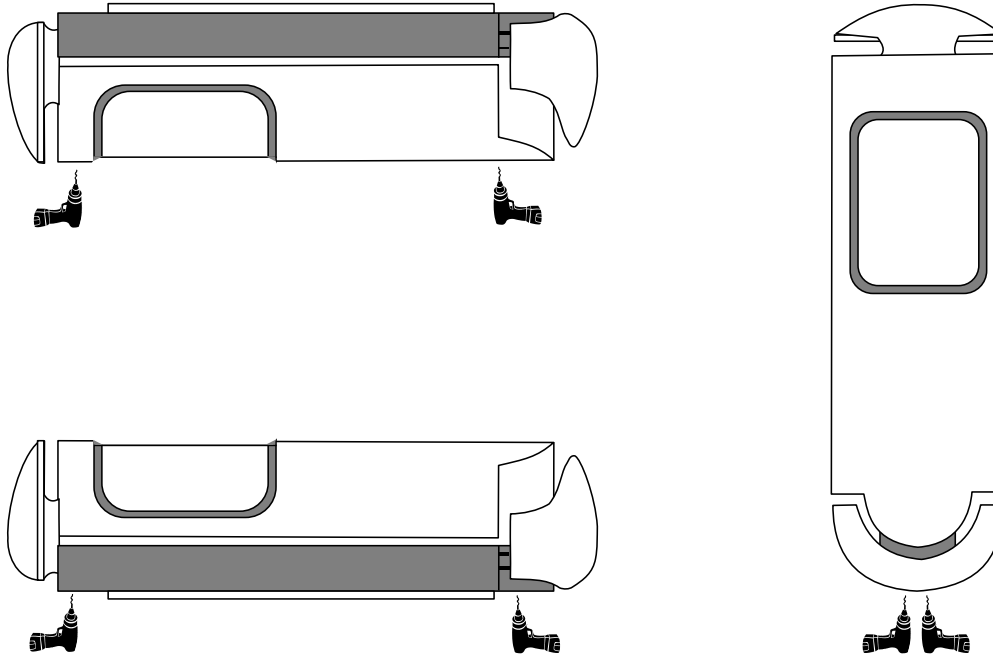

2.5 Enclosure Dimensions and Layout

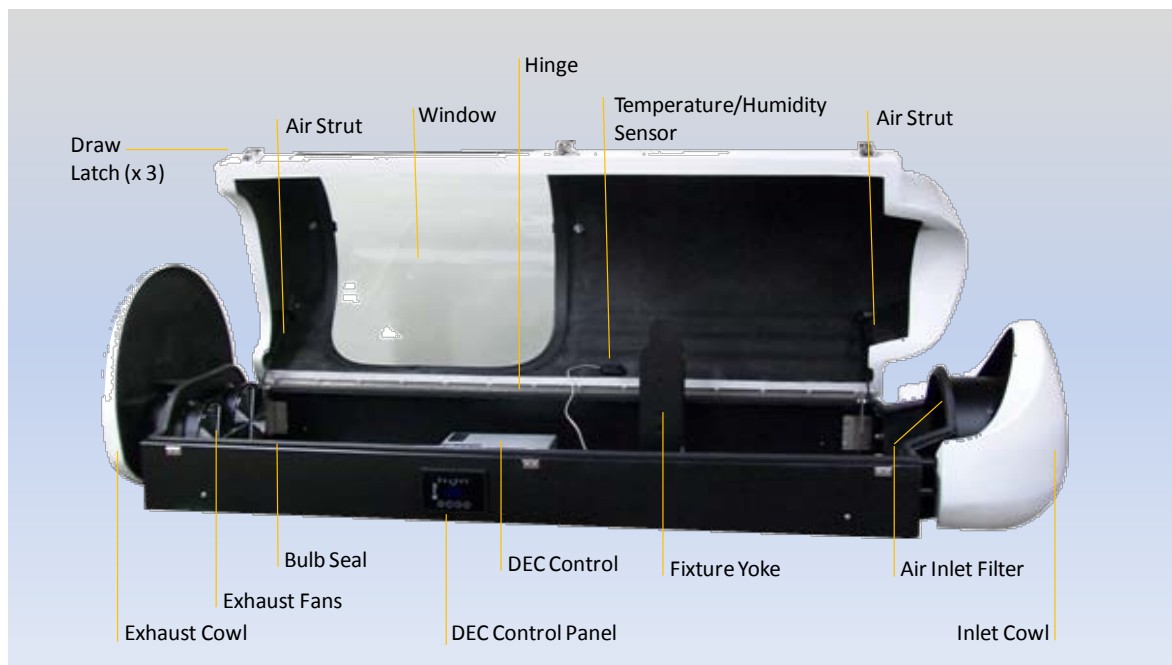
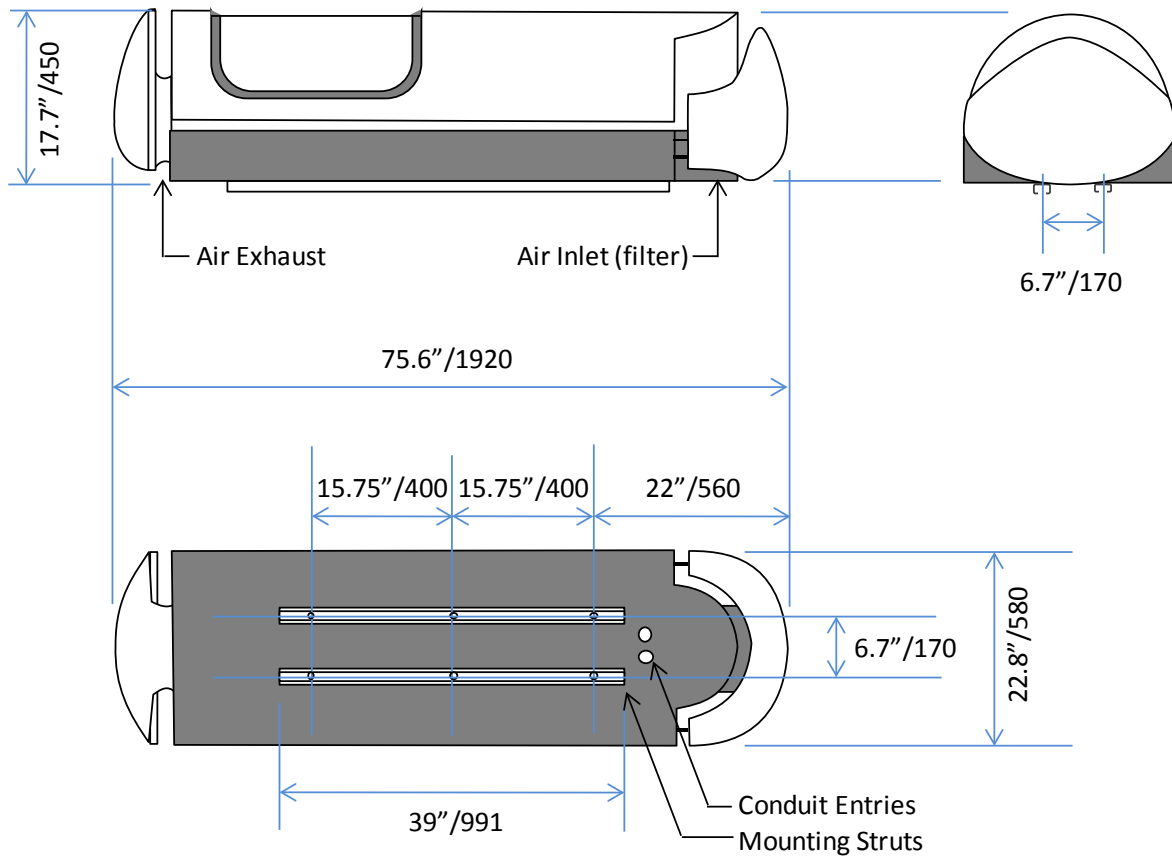

3 Wiring

3.1 Electrical Preparation

- ⚡ All electrical work must be carried out by a properly licensed electrician. Failure to observe this point will void the factory warranty for the Tempest Enclosure and possibly the luminaire/projector.
- 1 Before starting work, switch off power to the branch circuit, carefully following lockout and tag-out procedures. Failure to do so could cause serious injury or death.
 - 2 Two electrical junction boxes will be required within a short distance of the Hurricane enclosure for:
 - AC Supply wiring
 - DMX Control wiring

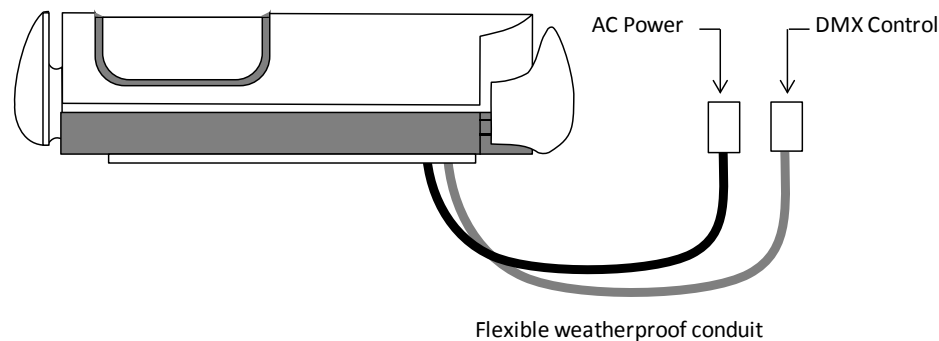

- 3 All junction boxes must be installed in accordance with local electrical codes and should be located near the permanent installation of the enclosure. Each junction box requires a length of 1/2" (20mm International) flexible weather-resistant conduit, long enough to reach from junction box to the enclosure conduit entries.
- 4 The AC supply must be 200-240VAC, and must be protected by a fuse or circuit breaker of a rating suitable for the projector, plus 650 watts max for the enclosure fans and heaters.
- 5 Connect the local junction box to the Hurricane enclosure using exterior grade flexible conduit. Pull suitably rated wires through the conduit to supply the Hurricane enclosure and connect as described below.
- 6 Alternatively, you may run separate AC feeds for the projector and the enclosure. Follow either single or double-feed wiring instructions below, according to preference:

3.2 Digital Enclosure Control

The Digital Enclosure Control (DEC3) system monitors power, data, temperature and humidity, and is the key to assuring long equipment life in your Tempest Enclosure. In the Hurricane enclosure, the DEC is located in the base, and is protected by an aluminum cover.

Remove the four nuts holding the cover in place to access the DEC for installation and setup.

Before installing the fixture in the Hurricane enclosure, replace the cover, taking care not to trap any wires.

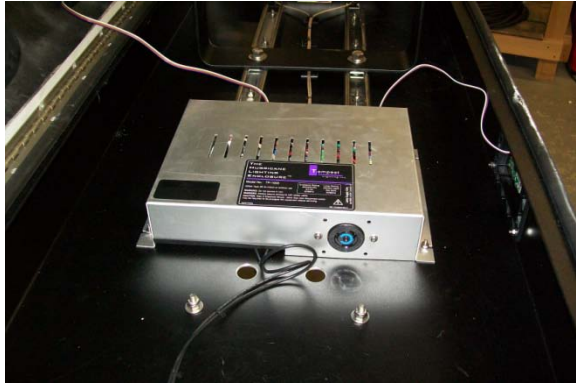

Digital Enclosure Control (DEC3) cover in place, showing US-Style L6-20 fixture receptacle (International version has a CE17 16amp receptacle).

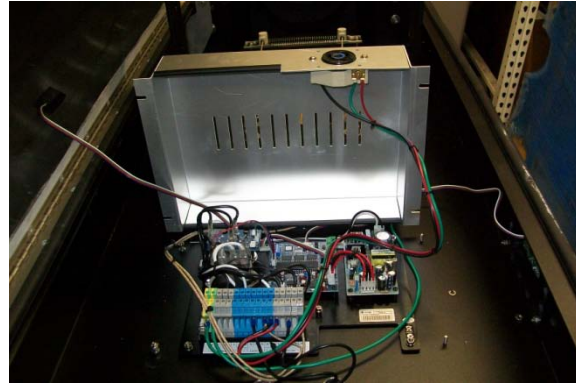

Digital Enclosure Control (DEC3) cover open, showing terminal block for power terminations.

4 DEC3 Control – Introduction

Tempest Lighting and Projector Enclosures have been in daily use around the world for almost a decade. Tempest enclosures protect expensive and delicate equipment in all climates, maintaining a comfortable operating temperature, and preventing condensation – the real outdoor enemy.

DEC3™ – that’s *Digital Enclosure Control, third Generation* – is the brain of your Tempest enclosure. It will maintain the internal environment in a comfortable temperature and humidity range, and prevent condensation – the real equipment killer. DEC3 monitors internal temperature, humidity and lamp current at all times, and uses this information to control its lamp relay, fan(s) and heater(s). It can report back over the DMX cable, using the RDM protocol (Remote Device Management) if desired.

Unless otherwise specified, this version of the user guide refers to DEC3 units fitted with software version 2.1 or later.

So, what does DEC3 actually DO?

DEC3 is the brains of the operation – here’s a layout:

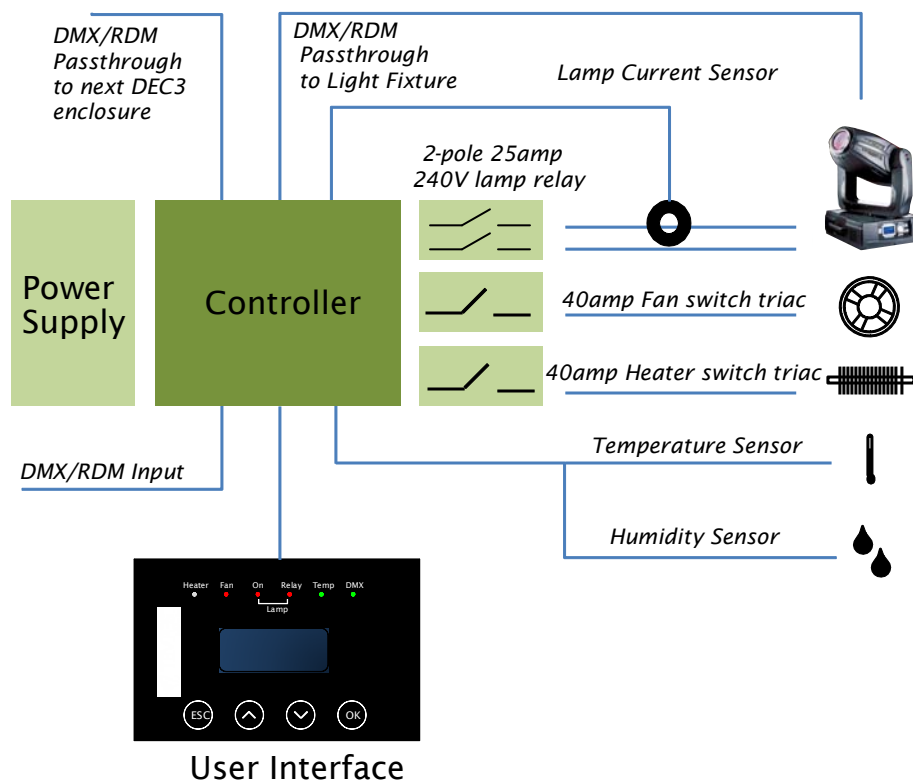

This schematic shows the relationship between DEC3’s functional elements. The power supply is universal 90-260V, but fans and heaters are either 120V or 230VAC, and must be so specified. A high-quality 25amp 2-pole electro-mechanical relay isolates fixture/projector power in the event of an over-temperature condition. Fans and heaters are switched using generously overrated 40amp Triac devices for maximum reliability. Two DMX outputs connect to the internal fixture (if desired) and on to other enclosures or DMX devices.

DEC3’s mission is to maintain temperature and humidity inside the enclosure, within determined bounds, and to prevent condensation – particularly overnight dew formation – inside the equipment housed. Condensation is fatal to electronic equipment, particularly in polluted areas or saline environments, where it brings not only rust and short-circuits, but also a steady buildup of mineral and/or salt deposits. Incidentally, condensation is very hard to control with air-conditioning type systems, which is why we don’t use them.

Broadly speaking, DEC3’s function depends on whether the fixture/projector lamp is on or off:

Lamp ON

When the projector/fixture is running, the heat from the lamp takes care of humidity, and DEC3 runs the enclosure's fan(s) to change its air every few seconds – ensuring minimal temperature rise above outside ambient.

Lamp OFF

When the lamp is off, DEC3 senses temperature and humidity and controls its fan(s) and heater(s) accordingly. When conditions are within normal bounds (between top and bottom temperature settings and below the humidity threshold (see below), DEC3 pulses the heater at a low level to dry the air and eliminate condensation, and runs the fans to change the enclosure air every 30 seconds or so. We call this 'pulse mode', and it is the key to preventing damaging condensation inside your equipment.

If the temperature rises above the top set limit (see below), DEC3 runs the fans to cool it down. In cold conditions, DEC3 will run the heater as required to maintain the bottom set temperature.

Thus, DEC3 maintains a comfortable operating temperature inside the enclosure, and prevents damage from condensation. Users all over the world have found that Tempest enclosures provide an optimal environment for expensive and delicate equipment, in every climate type.

And while doing all of this, DEC3 can tell you what's happening over your RDM network – a real boon in larger installations.

4.1 Operating Modes

DEC3 may be run in one of three basic operating configurations. A fourth configuration is provided for test and service use.

Standalone: The enclosure operates independently, and automatically, requiring no user intervention. User may set parameters such as temperature and humidity thresholds, and monitor sensor information and DEC status at the DEC3 user interface. Standalone is the default DEC3 shipping mode unless specified otherwise at time of order. DMX is not required or utilized.

DMX/RDM Mode 1 (RDM Monitor)

All of the Standalone features plus the ability to discover and monitor the DEC3 over a DMX512 connection, using RDM.

In this mode, the DEC3 does not need to “see” any DMX to operate. The mode allows the use of RDM to set the various temperature thresholds, and monitor the conditions inside the enclosure remotely. The fixture inside the Tempest enclosure may also be an RDM enabled device.

DMX/RDM Mode 2 (DMX Enable)

All of the Standalone and RDM Monitor features plus the use of a single DMX address (slot) to control the Lamp Relay.

This means that the user is responsible for maintaining a DMX input with the slot (as selected as the DMX START ADDRESS on the DEC3) high. This slot level must be set greater than 50% at all times when the internal fixture is to be powered. This has the useful attribute of enabling the user to remotely force a hard reset of the fixture by opening and then closing the Lamp Relay. It also means that it is unnecessary to feed the enclosure with two power sources (for the enclosure and the luminaire/projector), since the DMX slot may be used to isolate the projector when not in use, without removing power from the enclosure. This mode is recommended for show-control applications, where it is desirable to have power control of the internal fixture, and accidental loss of the DMX data is very unlikely to occur.

In the absence of DMX, the Lamp Relay defaults to “ON”.

All RDM functions are available for configuration and monitoring of the DEC3.

DMX/RDM Mode 3 (Service/Test)

This mode is intended for test and service use.

It gives the user direct control of the lamp, fan and heater relays over DMX. User may NOT override any of the relays in an unsafe direction – for example, if the DEC3 has determined the enclosure is over-temperature and has switched off the lamp relay, the relay may not be overridden ON by DMX. In this sense, DMX ‘piles on’ to DEC3 operation, within defined safety limits. However, until such time as

the temperature reaches the TOP limit, the heater may be enabled and the fan disabled, which is why the mode should only be used for Test and Service use.

If the DEC3 has been purchased with DMX/RDM enabled, it is possible to select the required mode 1-3 using RDM. In the RDM context, this is known as selecting the device’s DMX PERSONALITY. Setup of the DEC3 from the Front Panel is available in all configurations.



RDM is an effective and powerful tool for commissioning and monitoring an installation, particularly in large systems. For further guidance, we recommend you consult a qualified RDM system integrator. If you don’t have one in your neighborhood, go to www.tempestlighting.com, and click on the RDM and RDM Integration bug on the home page for some useful contacts. Tempest Lighting warrants DEC3 to be compliant with the RDM standard, but is not an RDM systems integrator, and can offer only basic guidance on RDM utilization.

4.2 DEC3 Control Parameters

DEC3 will run out of the box with its default parameter settings, which equate to the (fixed) settings of its predecessor DEC’s 1 and 2.

Temperature:

- Top Set** *Range 35-45°C, Default = 40°C*

Most manufacturers recommend a max temperature for their equipment of 40°C, though this does vary. When DEC3 senses a temperature higher than Top Set, it indicates an overtemp condition as a warning. NOTE: in moving light enclosures the thermal sensor is necessarily placed in the exhaust air path, which will be higher (sometimes a lot higher) than the actual fixture ambient. This needs to be kept in mind when adjusting temperature settings.
- Cutoff Temp** *Range 0-15°C, Default = 15°C*

This is a setting *above* the Top Set temperature that determines the temperature at which the lamp relay is opened, cutting off power from the fixture/projector. The user may reduce it as desired, but should establish before doing so the actual operating temperatures experienced in hot weather before doing so, to avoid nuisance tripping.
- Bottom Set** *Range 0-10°C, Default = 10°C*

The temperature maintained by the heater in cold conditions. Most equipment manufacturers recommend a minimum operating temperature of 0°C, and users may set it lower than the default if desired.

The threshold at which incoming air is more aggressively heated to remove moisture. This parameter will not normally require adjustment.

DMX Set *Range 001-510, Default 001*

Sets the DMX address for the lamp relay control. In the DMX/RDM service mode, the subsequent two DMX slots control fan and heater respectively.

Lamp Hours *Default 0000*

DEC3 counts the hours your projector/fixture lamp is on, and can report it both on the user interface display and over RDM. **Remember to reset to 0 when changing lamps.** This is provided to allow lamp hours monitoring on devices such as Video Projectors and certain moving lights that have no native RDM or DMX support.

4.3 Operating Mode Setup

Your DEC3 will normally be factory set to the operating mode you specified in your order:

Operating Mode DIP Switch Settings

Mode	DIPswitch Settings	Mode Summary
Standalone	1-6 OFF	Standalone - no DMX/RDM
DMX/RDM	2 ON, 1, 3-6 OFF	DMX/RDM Modes 1-3 - support for remote monitoring

4.4 DMX Connections

DMX refers to USITT DMX512, a commonly used control protocol in the entertainment industry, running over RS485. Consult USITT DMX installation guidelines when laying out a system, or employ a qualified DMX system integrator.

Note that DMX is optional - in many applications it is not required, and need not be connected.

DMX IN - Connect incoming DMX to the 2-part 3-pin terminal on the DEC3 control circuit board so labeled.

Pinout: (1) Ground, (2) Data -, (3) Data +.

DMX THRU - there are two DMX pass-through terminals - one for a fixture inside the enclosure, the other to run to the next DMX device in the network. Pinout: same as DMX IN.

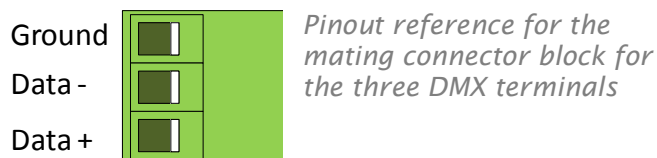
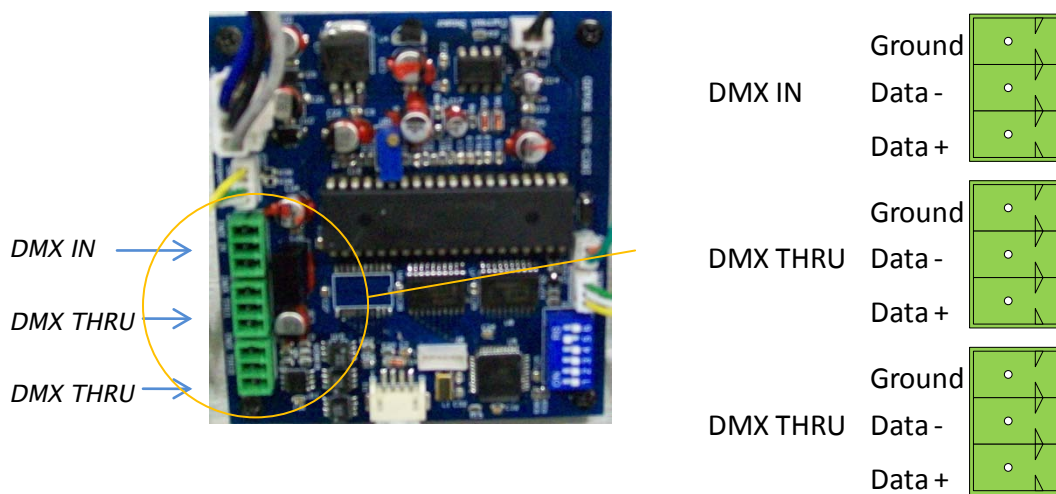

4.5 DMX Line Terminations

DMX cable runs must be terminated at the far end of the cable run with a termination resistor as detailed in the DMX standard. This is particularly important for satisfactory operation of DMX/RDM installations. The individual fixtures installed inside the Tempest enclosures must NOT be terminated. It is recommended that any line termination is done using the 3-pin terminal connector fitted to the DEC3 control circuit board.

1. Make sure that any DMX termination provided by the fixture inside your enclosure(s) is disabled.
2. The LAST enclosure in the installed DMX daisy chain should have a DMX Termination fitted to one of the pass through DMX connectors. Per the ANSI E1.11 standard, the Terminator shall be 120 ohm +5%/-10% impedance placed between Data+ and Data-. We recommend minimum power rating of 0.6W for the resistor.
We recommend that the installer fit a label externally to say "DMX Termination fitted internally".

Test:

3. Switch mains power OFF to all enclosures.
4. Before connecting the DMX line to your controller, measure the impedance between Pin 2 (Data-) and Pin 3(Data+) at the controller end. Reading should be around 100-130 ohms.

This test shows that you have a terminator in place, and also that you have continuity of Data- and Data+ between installed devices. If the measured resistance is significantly less than 100 ohms, (say 40-80 ohms) it suggests you may have multiple terminations in place. Check that any terminator switches on light fixtures are OFF. If impedance is very low, check for wiring shorts.

4.6 RDM Connections

RDM refers to ANSI E1.20, a control protocol in the entertainment industry gaining popularity and essentially an "extension" of DMX512. The use of RDM is optional - but it does require a DMX512 cable connection.

4.7 Important – RDM and RDM Integration

RDM (Remote Device Management) is an ANSI standard that adds bidirectional discovery and status monitoring to a standard DMX network connection. No additional wiring is required for RDM operation.

DEC3's RDM implementation allows system integrators to set up remote control and status monitoring of all attributes and sensors, including:

- Temperature
- Humidity
- Lamp Current
- Elapsed Lamp Hours
- Lamp Relay Status
- Fan Relay Status
- Heater Relay Status

- DMX Status
- DMX Start Address
- DMX Personality (RDM Mode)
- Device Type
- Device Label
- Software Version

Tempest Lighting warrants that its RDM products are compliant to the RDM standard, but does not directly support RDM system integration. Tempest Lighting will however provide introductions to qualified RDM system integrators for customers requiring assistance in this area. Links are provided on the Tempest Lighting web site (www.tempestlighting.com).

4.8 Control Interface

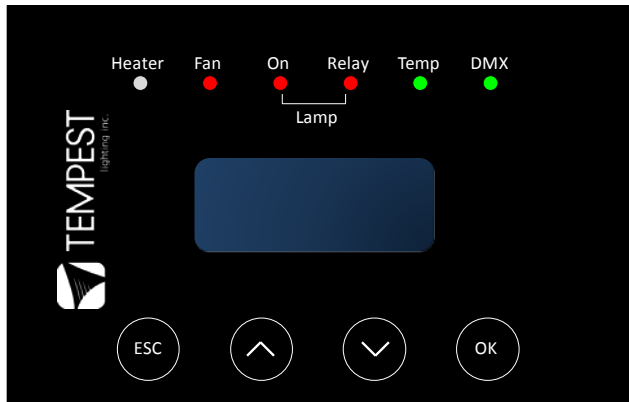

The control interface features a 2-line display, LED indicators, and 4 cap-sense control buttons.

LED Indicators

Heater

SHORT PULSE (RED) - Indicates lamp is off, and the heater is pulsing to prevent condensation inside the enclosure and projector/light fixture. This is normal operation when the lamp is off and the temperature range is above the bottom set limit.

ON (RED) - Indicates heater is on, due to temperature being below bottom temperature setting when lamp is off.

OFF - indicates lamp is on and maintaining temperature above bottom limit.

Fan

SHORT PULSE (RED) - The fan is moving a little air through the enclosure, as part of the condensation prevention strategy. The fan comes on for a few seconds approximately every 30 seconds.

ON (RED) - Indicates fan is running, due to lamp being on or internal temperature exceeding top limit.

Lamp Relay

ON (RED) Indicates lamp relay closed and power is available to the internal fixture/projector.

OFF Indicates lamp relay open and power is removed from the internal fixture.

Lamp On

ON (RED) Indicates current sensed on the lamp circuit greater than 1 amp (this allows some current to be drawn for such things as fans and control electronics without the Lamp On indicator lighting. When the Lamp On indicator is on, the lamp counter is counting lamp life.

Temp

ON (GREEN) - The temperature is between Bottom and Top temperature settings.

FLASHING (RED) - The temperature is above Top setting but has not yet reached the Cutoff level.

ON (RED) - Temperature is above Cutoff level or below Bottom level.

DMX (only used when DMX/RDM setting is in effect)

ON (RED) - DMX error.

ON (GREEN) - Good DMX or RDM data packet received.

4.9 Control Interface Operation

The Control Interface is normally LOCKED.

To UNLOCK, touch ESC and OK together for 5 seconds.

You are now in the **CONTROL MENU**

Use the arrow keys to scroll up and down the menu.

Use OK, to enter a menu item, then the arrow keys to set the item parameter, or to scroll to the next menu level.

Use ESC to back up a level, and OK to confirm settings.

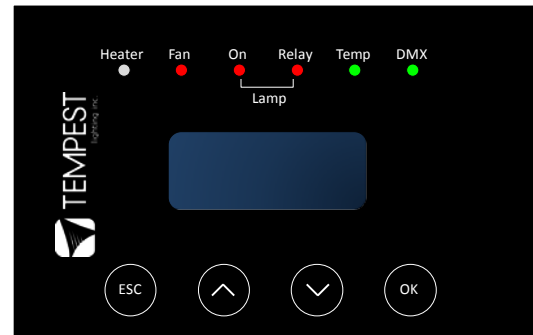

Depending on the Operating Mode selected, and present status, DEC3's display shows you temperature, humidity, DMX address and a selection of error and status messages.

CONTROL MENU

DMX SET (if DMX/RDM mode 2 or 3 is selected)

Select a DMX starting address in the range 001 to 510

1 - Lamp Relay

In RDM Mode 3 an addition two slots are required

2 - Fan Relay

3 - Heater Relay

Note that the DMX control is designed using a SAFETY pile-on Logic. In other words, the DMX input can only override automatic settings in a safe manner. For example, if the enclosure has switched off the lamp relay due to an over-temperature condition, the DMX input cannot switch it on, if the fans are running because of Overtemp, the DMX input cannot turn them off, and so on.

The DMX SET menu can be ignored if the DEC3 is in Standalone or DMX/RDM Mode 1 (RDM Monitor) mode.

SET LAMP HOURS TO 0

The lamp hour counter needs to be reset each time you change the lamp in the fixture/projector. Make this a part of your maintenance instructions.

STATUS DISPLAY

View Temperature (in Celsius) and Relative Humidity (in %) inside the enclosure. Note that in Tornado moving light enclosures the temp/humidity sensor is located in the exhaust airflow, which may be significantly warmer than ambient.

HUMIDITY SET

The humidity level above which the heater kicks in to remove humidity from incoming air (default 80%, permissible range 50-90%). This setting should not normally be changed.

TEMP SET

Set three temperature trigger points for Top, Cutoff and Bottom temperatures.

TOP TEMP

The desired upper temperature limit for normal operation (default 40°C, permissible range 35-45°C).

When the DEC3 sees air above this temperature, but below the additional Cutoff temperature (see below), it indicates a temperature error. This is not dangerous, but may reduce lamp life.

CUTOFF TEMP

The desired upper temperature ABOVE the TOP TEMP setting, at which the lamp relay is forced to open, isolating the fixture/projector power.

(default 15°C, permissible range 0-15°C).

To avoid nuisance tripping, set this variable to the maximum, and monitor actual temperatures in your normal operating conditions. If your actual temperatures are running lower, then you may reduce the cutoff temperature margin. In hot climates, it may be advisable to set both TOP TEMP and CUTOFF TEMP as high as possible.

BOTTOM TEMP

The desired lower temperature limit for normal operation

(default 10°C, permissible range 0-10°C).

Note that a higher BOTTOM TEMP may provide additional protection against condensation in some conditions, but will consume more energy. Therefore a lower setting is desirable, provided the user is certain that no condensation is occurring.

RDM MODE SET

The RDM Mode is normally set using RDM commands from a remote RDM control device to set the DMX PERSONALITY of the DEC3.

From the DEC3 user interface, this menu item allows the user to check (and if necessary alter) the RDM mode. Please ensure that the DEC3 is NOT unintentionally left in Mode3 (Service/Test).

5 Mounting the Projector in the Hurricane Enclosure

 For safety, this must be done by two or more people.

IMPORTANT: The Hurricane enclosure MUST be securely mounted BEFORE you attempt to install the projector.

1. Your Hurricane enclosure is normally supplied with a low-profile yoke already installed, for use with the scanner type specified on your order. These will vary slightly, depending on fixture type.
2. Note carefully how the yoke supplied with your scanner fixture is attached to the fixture.
3. Remove the original yoke supplied with your projector and keep the securing hardware.
4. Carefully place the projector in the yoke mounted in the Hurricane enclosure, and attach it using the hardware removed from the original yoke.
5. MAKE SURE THAT THE MIRROR IS FACING UP (away from the enclosure base), and is positioned approximately center to the projection window. You can move the yoke along its mounting strut to adjust this if you need to.
6. Check that all mounting bolts are tight and secure.
7. Plug the fixture into the receptacle in the DEC cover, and connect the DMX control in compliance with the fixture manufacturer's installation manual.

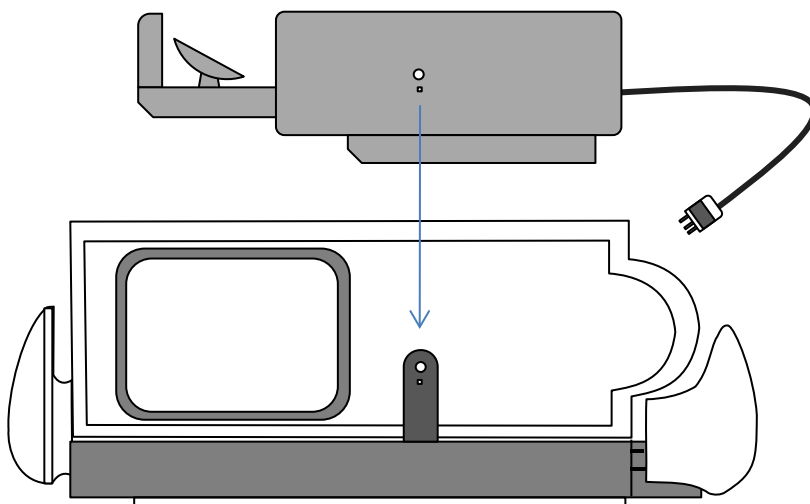

6 Activation and Checkout

Now the installation is complete, the time has come to activate the enclosure and make sure it is working properly.

 Be aware that once the enclosure has had power applied to it, the heaters will get hot and the fans will start to turn. Make sure that your hands and any cables or other objects are clear of both of these areas before applying power to the enclosure.

1. Clear enclosure and projectors of all debris.
2. Set up the projector in accordance with the manufacturer's instructions.
3. Focus the projector, then close the enclosure cover.
4. The system is now ready for use.

Note

The enclosure can be secured with padlock at this point. Only qualified personnel should be accessing the enclosure.

7 Operation

See section 4 for detailed operating instructions.

- ① **Regardless of whether the projector is in use, power must be maintained to the enclosure at ALL TIMES. The Digital Enclosure Control system will work 24/7 to ensure that optimum temperature and humidity are maintained, preventing condensation, overheating and freezing. This is critical to attaining optimum projector lifetime.**
- ① The cooling fans will only turn when power is applied to the enclosure. Fans will stop turning when power is cut to the enclosure, but the heater may remain hot to the touch for up to one hour - be careful when opening the enclosure immediately following a power down.
- ① Unless the enclosure or projector is undergoing routine maintenance, the enclosure should be closed and securely latched at all times.
- ① Only authorized personnel should open the enclosure (see maintenance warnings in the next chapter).
- ① If the safe operating temperature is exceeded, the over-temperature shutdown feature may engage and temporarily cut off power to the projector. Once the temperature reaches acceptable levels, power will be automatically restored. This is extremely unlikely to occur during hours of darkness when the projector is in use. To avoid nuisance cutoffs, set the Top Temp and Cutoff Temp settings to their maximum (see chapter 4)
- ① **Do not** routinely operate projector in full sun in hot weather. The enclosure has not been designed to protect the projector in this extreme condition.





8 Routine Maintenance

It is very important to perform routine maintenance on both the enclosure and the projector inside it. Failure to do so may reduce lifetime for both the enclosure and the projector.

Note

Maintenance schedules depend on location and environment. The intervals given here are general minimum guidelines. It is up to the user to judge whether maintenance should be carried out more frequently. We recommend doing these tasks no less often than mentioned here.

Safety

-  As the enclosure is a powered unit with moving parts, it is necessary to keep safety in mind while performing routine maintenance. Although maintenance can be performed while the enclosure is powered, it is safer to carry it out with the power disconnected with proper lockout and tag out procedures followed.
-  Be aware that once the enclosure has had power applied to it, the fans will start to turn. Make sure that your hands are clear of the fans before applying power to the enclosure.
-  Only authorized personnel should perform maintenance on the enclosure or luminaire
-  Do not service the unit in the rain or other adverse weather conditions (snow, sleet, high winds, etc.).

Inspection Checklist: - Every Three (3) Months

- Glass should be clean and free of cracks
- Enclosure should be free of debris both inside and out
- Bolts should be tight
- All safety cable should be in good condition
- Door seals should be in good condition. Check seals inside and out for gaps.
- Fans should be functioning and not making excessive noise
- Fan filters should be clean
- Drainage holes free of obstruction

Air Filters - Every Three (3) Months

The air filter from the intake vent on rear of enclosure (left side) should be removed and cleaned on a regular basis. To remove filters, open the enclosure, reach into the inlet duct, and pull out the filter. The filters can be cleaned by running water from a hose and do not require any special cleaning solution.

To reinstall, push filter fully back into the inlet duct until it presses on the inside of the inlet cowl. The filter will be held in place by velcro tabs.

Warning: Make sure that the filter is never left in contact with the heater, when the enclosure is in use.

Replacement filters may be obtained from your Tempest Lighting Dealer.

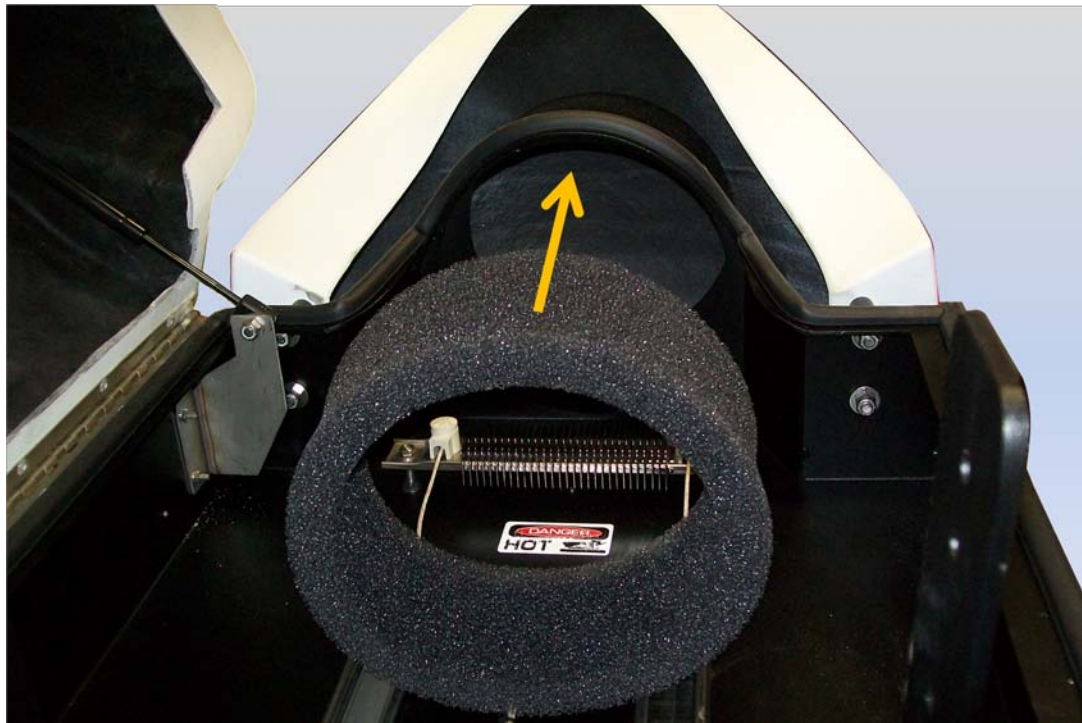

Case - As Needed

The outside of the case should be cleaned as needed. The case should be cleaned with a wet cloth and mild detergent (if necessary). Do not use a direct spray from a hose to clean the case. Do not use hydrocarbon-based cleaners.

Window - As Needed

Clean using a proprietary glass cleaning solution or a mild detergent, and wipe dry. Use only soft, lint-free cloths for glass cleaning. Never use an abrasive cleaner.

Projector

Review the manufacturer's instructions for proper maintenance of your luminaire/projector. Remember, the enclosure simply protects the equipment inside it and is not a substitute for regular maintenance.

9 Troubleshooting

This is a guide to the general symptoms, problems, and solutions that may occur during the usage of your enclosure. However, it is important to remember that problems may occur within the luminaire itself and these must also be considered.

Projector does not have power.

Check power supply wiring and voltage.

One or more fans are not spinning

Fans may be obstructed. Shut off power to enclosure and check for obstructions. Turn power back on to see if fans will start spinning. If fans do not turn and display on temperature controller is lit, contact technical support. If fans do not turn display is not lit, then enclosure is not receiving power. Turn off all power and check wiring. If the wiring is correct, contact technical support.

Fan cords may have become disconnected. Check connections between fan and cord. Make sure that the ribbed side of the cable is on the positive side of the connection (the fans are DC powered).

Projector does not have power.

Check projector power switch. (Note: the following actions should be performed by a licensed electrician) If switch is on, check wiring (including metering supply voltages, enclosure must receive 200-240VAC to operate properly).

In case of over-temperature, the enclosure shuts down power to the projector, for its protection. Projector power will be restored when temperature drops to an acceptable level. It is possible that the air intake or exhaust has become clogged, leading to higher temperatures inside the enclosure. Make sure that these areas are clear, the filters are clean, and the fans are working properly.

Projector turns on and off repeatedly over short span of time.

Check that vent areas and airways are clear. If so, ambient temperature may be too high (see over-temperature note above) or projector may have internal problem.

Excessive water in enclosure.

Glass seal leak. Repair with silicone sealant.

Door gaskets leak caused by separation. Silicon piece back into place or replace section.

10 Sample Specification

Unit shall be a Tempest Hurricane lighting enclosure catalog number 1000-__-__. The housing shall be constructed from aluminum, fiberglass and stainless steel. Further, the unit shall possess filtered forced air ventilation in combination with heater and controlled by a microprocessor with a temperature display. Unit shall be designed to U.L. standard 508 for wet locations and be a NEMA type 3R. The unit shall have above ground connection ports, compression latches with padlock rings, and may be secured to its mounting via stainless steel Unistrut members. Unit shall provide a power cutoff to fixture in case of high temperature inside enclosure. Units shall control cool-down rate of projector by use of heater. Unit shall have a projection window with optically clear safety glass. The enclosure shall be identified as The Hurricane Enclosure manufactured by Tempest Lighting, Inc., of North Hollywood, California, USA.

11 Limited Warranty

What is covered. Exclusions.

Unless otherwise stated, your product is covered by a one (1) year parts and labor limited warranty. Factory-painted product is not guaranteed against scratches. It is the Owner's responsibility to furnish receipts or invoices for verification of purchase date, and dealer or distributor. If purchase date cannot be provided, date of manufacture will be used to determine start of warranty period. Unless otherwise specifically stated in writing, all warranty work is carried out at the Tempest Lighting factory. In the event that the Owner purchases any optionally available on-site check-out or turn-on services, Owner agrees to provide facilities to perform such services at ground level. Tempest Lighting does not in any way offer any warranty for the luminaire.

Owner Responsibility for Installation.

Tempest Lighting makes no recommendations for mounting any Tempest Lighting product. It is the sole responsibility of the Owner to perform any necessary structural, electrical, environmental or other appropriate analysis prior to installing any Tempest Lighting product.

Returning an Item Under Warranty for Repair.

It is necessary to obtain a Return Material Authorization number (RMA#) from your dealer or point of purchase BEFORE any units are returned for repair. The manufacturer will make the final determination as to whether or not the unit is covered by warranty.

Any Product unit or parts returned to Tempest Lighting, Inc., must be packaged in a suitable manner to ensure the protection of such Product unit or parts, and such package shall be clearly and prominently marked to indicate that the package contains returned Product units or parts and with a Return Material Authorization (RMA#) number. Accompany all returned Product units or parts with a written explanation of the problem or malfunction.

NOTE: *Freight Damage Claims are invalid for fixtures shipped in non-factory boxes and packing materials. These materials can be supplied if requested, at additional cost. It is recommended that all packaging material be retained for possible re-use.*

Freight.

All shipping charges must be prepaid by the Owner. Items under warranty shall have return shipping paid by the manufacturer only in the Continental United States. Under no circumstances will freight collect shipments be accepted. Prepaid return shipping does not include expediting such as airfreight. Airfreight will ship customer collect.

REPAIR OR REPLACEMENT AS PROVIDED FOR UNDER THIS WARRANTY IS THE EXCLUSIVE REMEDY OF THE CONSUMER. TEMPEST LIGHTING, INC. MAKES NO WARRANTIES, EXPRESS OR IMPLIED, WITH RESPECT TO ANY PRODUCT, AND TEMPEST LIGHTING SPECIFICALLY DISCLAIMS ANY WARRANTY OF MERCHANTABILITY OR FITNESS FOR A PARTICULAR PURPOSE. TEMPEST LIGHTING SHALL NOT BE LIABLE FOR ANY INDIRECT, INCIDENTAL OR CONSEQUENTIAL DAMAGE, INCLUDING LOST PROFITS, SUSTAINED OR INCURRED IN CONNECTION WITH ANY PRODUCT OR CAUSED BY PRODUCT DEFECTS OR THE PARTIAL OR TOTAL FAILURE OF ANY PRODUCT REGARDLESS OF THE FORM OF ACTION, WHETHER IN CONTRACT, TORT (INCLUDING NEGLIGENCE), STRICT LIABILITY OR OTHERWISE, AND WHETHER OR NOT SUCH DAMAGES WERE FORESEEN OF UNFORESEEN.

Warranty is void if the product is misused, damaged, modified in any way, or where unauthorized repairs or parts have been employed. This warranty gives you specific legal rights, and you may also have other rights, which vary from state to state.

12 Tempest Product Support

Step 1: First contact your local Dealer for support. Your dealer is best placed to respond quickly to your needs.

Step 2: If your dealer is unable to answer your questions please contact:

Tempest Lighting, Inc.

13110 Saticoy Street, CA 91605 USA

Tel +1 818 787 8984

Fax +1 818 982 5582

info@tempestlighting.com

Visit our web site for current information and specifications:

www.tempestlighting.com

13 Registration

Filling out the registration form on the next page and sending it to the Tempest Lighting factory within 30 days of installation entitles you to the warranty cover specified in this manual. It also enables us to notify you in case of important news or post-sale information regarding the Hurricane Lighting Enclosure.

Hurricane Enclosure Registration Form

Detach and mail/fax to:

Tempest Lighting, Inc., 13110 Saticoy St., N Hollywood, CA 91605

Fax # +1 818 982 5510

If a Tempest Representative has not inspected the installation, please send photos showing installation.

Model Number:

Serial Number:

Latch Key Number:

Dealer/Sold By

Name:

Location:

Date Purchased:

Contractor/Installed By

Name:

Date Installed:

Location Installed:

Company/Organization

Name:

Street Address:

.....

City, State, ZIP, Country:

.....

Phone:

Fax:

Contact Information

Name:

Phone: Extension:

Fax:

E-mail: