

## User Manual and Installation Guide



### *Thunder Lighting Enclosures*

Download

September, 2010

You can download a copy of this manual at  
<http://www.tempestlighting.com/products.html#thunder>

**Tempest Lighting Inc.**  
13110 Saticoy Street, Unit # C  
North Hollywood, CA 91605, USA

Tel +1 818 787 8984  
Fax +1 818 982 5582  
[info@tempestlighting.com](mailto:info@tempestlighting.com)

*In the interest of continuous product improvement, the information in this document is subject to change without notice. Neither Tempest Lighting, Inc. nor its representatives or agents may be held liable for expense or injury arising from it.*

© Tempest Lighting Inc. All Rights Reserved



## Declaration of Conformity

This is to certify that the following products

- 6600.INThunder 6600 Enclosure
- 6610.INThunder 6610 Enclosure, DEC3 Control
- 6650.INThunder 6650 Scan Enclosure
- 6660.INThunder 6660 Scan Enclosure, DEC3 Control
- 6700.INThunder 6700 Enclosure
- 6710.INThunder 6710 Enclosure, DEC3 Control
- 6750.INThunder 6750 Scan Enclosure
- 6760.INThunder 6760 Scan Enclosure, DEC3 Control
- 6800.INThunder 6800 Enclosure
- 6810.INThunder 6810 Enclosure, DEC3 Control
- 6850.INThunder 6850 Scan Enclosure
- 6860.INThunder 6860 Scan Enclosure, DEC 3 Control

are in Compliance with the following standards or specifications according to the EMC Directive 89/336/EEC:

EN55015, EN61000-3-4, EN61000-3-5, EN61000-4-2, EN61000-4-3, EN61000-4-4, pr EN61000-4-5, EN61000-4-6, EN61000-4-8, EN61000-4-11

and are in compliance with the following standards or specifications according to the Low Voltage Directive 73/23/EEC.

EN60598-1

This declaration is made by the manufacturer

**Tempest Lighting, Inc.**  
13110 Saticoy Street, Unit C  
North Hollywood, CA 91411, USA

This declaration is based on tests that were conducted on the submitted samples of the above-mentioned products. Detailed results can be referred to test reports CET.TE200909 and LVT.Te200909.

Dated: October 26<sup>th</sup>, 2009  
Signature . . . . .  
Tempest Lighting Inc



## 1 Introduction

Thank you for purchasing the Thunder enclosure. It will serve you for many years, protecting your stage spotlights and effects equipments from the elements.

### Products Covered By this Manual:

6600.IN	Thunder 6600 Enclosure	230V
6600.US	Thunder 6600 Enclosure	120V
6610.IN	Thunder 6610 Enclosure, DEC3 Control	230V
6610.US	Thunder 6610 Enclosure, DEC3 Control	120V
6650.IN	Thunder 6650 Scan Enclosure	230V
6650.US	Thunder 6650 Scan Enclosure	120V
6660.IN	Thunder 6660 Scan Enclosure, DEC3 Control	230V
6660.US	Thunder 6660 Scan Enclosure, DEC3 Control	120V
6700.IN	Thunder 6700 Enclosure	230V
6700.US	Thunder 6700 Enclosure	120V
6710.IN	Thunder 6710 Enclosure, DEC3 Control	230V
6710.US	Thunder 6710 Enclosure, DEC3 Control	120V
6750.IN	Thunder 6750 Scan Enclosure	230V
6750.US	Thunder 6750 Scan Enclosure	120V
6760.IN	Thunder 6760 Scan Enclosure, DEC3 Control	230V
6760.US	Thunder 6760 Scan Enclosure, DEC3 Control	120V
6800.IN	Thunder 6800 Enclosure	230V
6800.US	Thunder 6800 Enclosure	120V
6810.IN	Thunder 6810 Enclosure, DEC3 Control	230V
6810.US	Thunder 6810 Enclosure, DEC3 Control	120V
6850.IN	Thunder 6850 Scan Enclosure	230V
6850.US	Thunder 6850 Scan Enclosure	120V
6860.IN	Thunder 6860 Scan Enclosure, DEC 3 Control	230V
6860.US	Thunder 6860 Scan Enclosure, DEC 3 Control	120V

### Using This Manual

Please read this manual in its entirety before starting work. All the information contained is important, and should be read carefully before proceeding. Heed all warnings and advisories.

### Icon Key:

① Valuable information







⚡ Electrical Warning

🚫 Safety Information

## 2 Installation





### 2.1 Safety and Warnings

These warnings are for your protection. Failure to comply may result in serious injury or death. Tempest Lighting, Inc. assumes no responsibility for damages or injury incurred by misuse or mishandling of product.



-  **Do not** attempt to install or operate the enclosure before fully reading and understanding this manual
-  **Never** allow anyone who has not read this manual to open the enclosure or perform maintenance on the equipment within.
-  **Never** leave the enclosure unattended when open.
-  **Always** make sure all bolts and latches are tight and safety locks are in place after performing any form of maintenance on the unit.
-  **Do not** open any electrical boxes until power has been shut off to all supply lines to the enclosure (including the one powering the equipment).
-  **Do not** open the enclosure in wet weather.

### 2.2 Tools and Equipment

To install the enclosure, you will need the following items:

-  Crescent wrench
-  Phillips screwdriver
-  Terminal screwdriver
-  Proper wiring installation equipment (for line power and signal wiring)
-  Any equipment listed in the equipment manufacturer's equipment-specific installation directions

### 2.3 Mounting the Thunder Enclosure

-  The Thunder enclosure must be mounted on or under a solid structure rated for the weight of the enclosure, the equipment inside it, and at least one person.
-  Snow – if installed outside in cold regions, the bottom of the Thunder enclosure must be at least 2' (60cm) above maximum height of any snowfall or drifting snow, subject to local conditions. If snow is not a consideration, then enclosure may sit on the ground as long as

proper drainage is provided.

- ① LEAVE ADEQUATE CLEARANCE BEHIND ENCLOSURE FOR WIRING AND VENTILATION
- ① *Tempest Lighting recommends the use of stainless steel mounting hardware.*

The Thunder enclosure is provided with a pair of Unistrut channels on the enclosure base, for mounting to your structure. You may use standard Unistrut accessories, or purchase either of the mounting kits available from Tempest Lighting – four kits are recommended per enclosure.

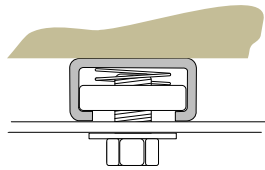

**4900.MB** *Stainless Steel Unistrut channel nut, bolt and washer. Four required per enclosure.*

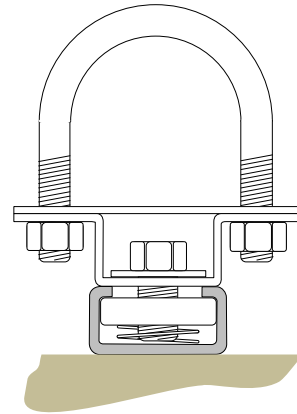

**4900.MC** *Stainless Steel Unistrut channel nut, bolt and pipe clamp, for pipes 1.5" (38mm) to 2" (50mm) OD. Four required per enclosure.*

**4925.MC** *Stainless Steel Unistrut channel nut, bolt and pipe clamp, for pipes 2" (50mm) to 2.5" (64mm) OD. Four required per enclosure.*

## 2.4 Mounting Base-down and Base-up

All Thunder enclosures are designed to be mounted base-down, on a solid structure, using Unistrut mounting hardware. They may also be suspended from an overhang, ceiling or truss, using the same hardware.

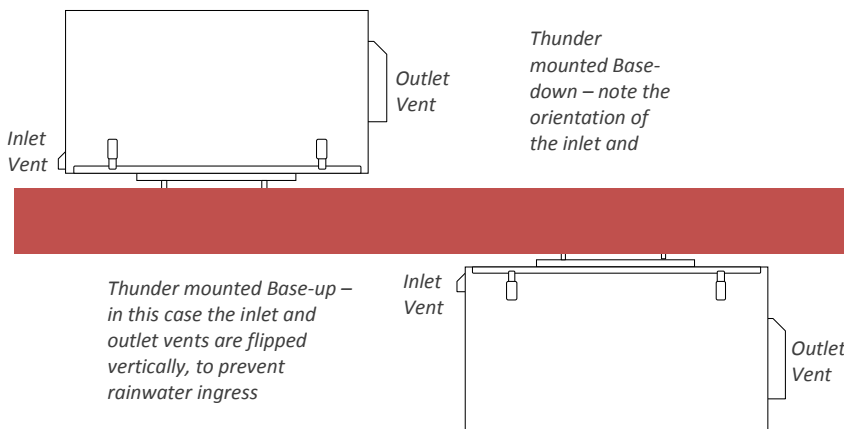

***It is the responsibility of the installer to ensure that all mounting points are secure and conform to local safety regulations. Tempest Lighting Inc. accepts no responsibility for damage or injury arising from inappropriate or unsafe installation.***

## 3 Wiring

### 3.1 Electrical Preparation

- ⚡ **All electrical work must be carried out by a properly licensed electrician. Failure to observe this point will void the factory warranty for the Tempest Enclosure and possibly the equipment/equipment.**
- 1 Before starting work, switch off power to the branch circuit, carefully following lockout and tag-out procedures. Failure to do so could cause serious injury or death.
  - 2 Two or three electrical junction boxes will be required within a short distance of the Thunder enclosure for:
    - AC Supply wiring (Equipment)
    - AC Supply Wiring (Enclosure Fan) – may be combined with equipment power feed if desired
    - Equipment picture signal wiring

Your Thunder enclosure is supplied fitted with two or three cable entry points, for Fan Power, Equipment Power and Equipment signal cables. In models with two cable entries, combine the fan and equipment power supplies into the cable entry in the electrical cover.

The cable entries are suitable for use with standard conduit fittings. US size ½", international 20mm. Tempest recommends the use of flexible, outdoor-rated conduit for the last few feet (1m) to the enclosure.

All junction boxes must be installed in accordance with local electrical codes and should be located near the permanent installation of the enclosure. Each junction box requires a length of flexible conduit, long enough to reach from the junction box to the enclosure conduit fittings. Leave slack for positioning of enclosure, and enough space behind the enclosure for ventilation.

The AC supply must be protected by a fuse or circuit breaker of a rating suitable for the equipment.

The user may connect the fan and the equipment to the same switched supply, or run them separately, according to need. If run separately, it is the user's responsibility to ensure that the fan is always running when the equipment is on.

## Fan- Only Enclosures

The following instructions apply to Thunder enclosures without DEC3 control.

- 1 Remove the electrical cover inside the enclosure. You will see the fan wires already terminated to the connector block on the rear panel.

Pass the AC feeder wires through the rear panel and terminate to the connector block, using one of the wiring diagrams below.

Replace the electrical cover, taking care not to pinch any of the power wires.

Plug the fixture into the AC outlet on the side of the electrical cover. Unless specified otherwise, 120V enclosures are provided with 15amp Edison receptacles, and 230V enclosures are provided with 16amp CE17 receptacles.



### 3.1 Wiring Diagrams

120V Dual Feed

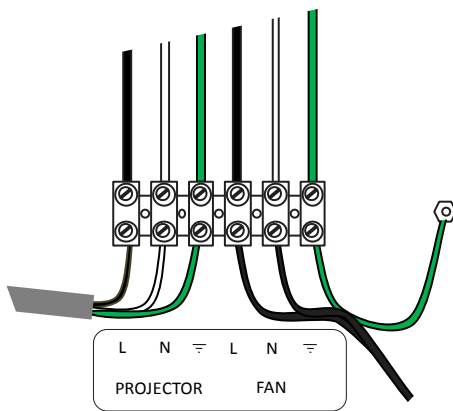

120V Single Feed

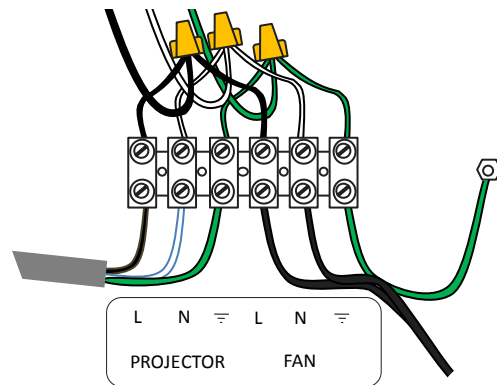

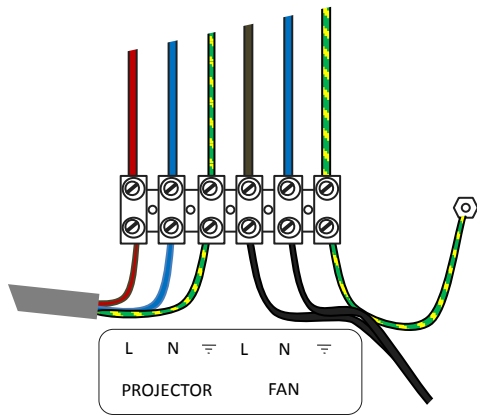
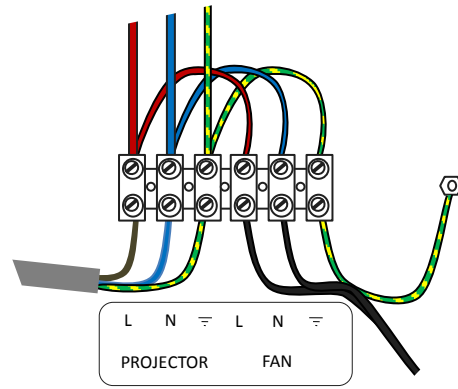
**230V Dual Feed****230V Single Feed**

- 6 Use the third cable entry to run equipment signal and control cables to the equipment, as specified by the equipment manufacturer.

Signal cables must NOT be run through the electrical compartment.

### 3.3 Wiring for DEC3 Versions

These instructions are for the installation of Enclosures featuring Tempest’s DEC3 Digital Environmental Control System (DEC3™). Your enclosure has DEC3 control if you see a control panel on the rear surface like this:

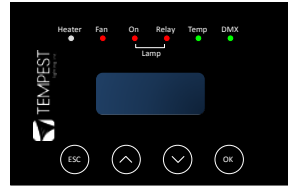

**IMPORTANT** Tempest enclosures are supplied for either 120VAC 50/60Hz, or 208-240VAC, 50/60Hz operation. Tempest Lighting is not liable for damage or failure to operate correctly due to connection to an inappropriate electrical supply.

**⚡ ⚡ ⚡ ALL ELECTRICAL CONNECTIONS MUST BE UNDERTAKEN BY A QUALIFIED ELECTRICIAN, IN COMPLIANCE WITH LOCAL NORMS AND STANDARDS.**

#### Split or Common Supply Wiring

**NOTE:** *Your enclosure MUST run 24/7, in order to protect equipment from condensation and temperature extremes.*

Tempest Enclosures are supplied wired for common electrical supply for the enclosure (DEC3) and the projector/light fixture to be enclosed. Customers wishing to provide independent electrical feeds to the enclosure and the projector/fixture must follow the instructions below.

#### Feeder Connections – Common Feed

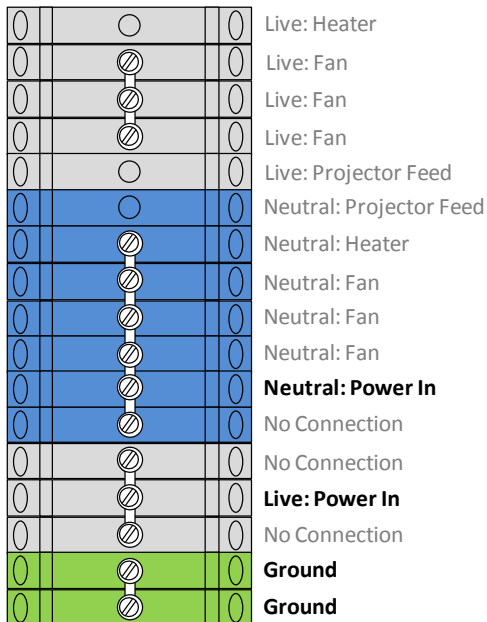

#### Feeder Connections, Split Feeds

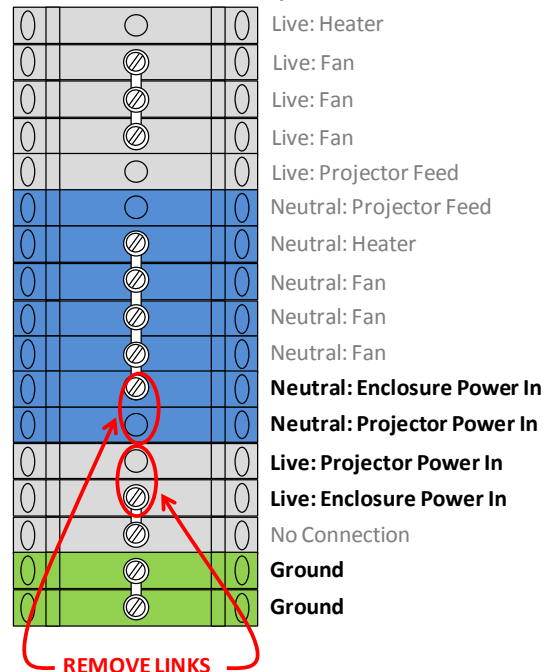

Note: terminals shown with gray text descriptors are factory wired and should not be changed. Only terminals shown with descriptors in black/bold font are for installer use.

DEC3 normally ships from the factory with power terminal links inserted for a common electrical supply to feed the enclosure and the projector/fixture inside it.

If you prefer to feed the enclosure and projector separately, remove the terminal links as indicated before connecting to mains power. Use a small flat-bladed screwdriver to remove the link, snap off the unneeded section and replace carefully. When splitting the feeders, we strongly recommend feeding both supplies from the same phase and at the same supply voltage.

### ***3.1 DMX Connections***

DMX refers to USITT DMX512, a commonly used control protocol in the entertainment industry, running over RS485. Consult USITT DMX installation guidelines when laying out a system, or consult a qualified DMX system integrator.

Note that DMX is optional – in many applications it is not required, and need not be connected. For more information, see DEC3 Operating Modes in the next section.

**DMX IN** – Connect incoming DMX to the 2-part 3-pin terminal on the DEC3 control circuit board so labeled.

Pinout: (1) Ground, (2) Data –, (3) Data +.

**DMX THRU** – there are two DMX pass-through terminals – one for a fixture inside the enclosure, the other to run to the next DMX device in the network.

Pinout: (1) Ground, (2) Data –, (3) Data +.

## DEC3 Control – Introduction

Tempest Lighting and Projector Enclosures have been in daily use around the world for almost a decade. Tempest enclosures protect expensive and delicate equipment in all climates, maintaining a comfortable operating temperature, and preventing condensation – the real outdoor enemy.

DEC3™ – that’s *Digital Enclosure Control, third Generation* – is the brain of your Tempest enclosure. It will maintain the internal environment in a comfortable temperature and humidity range, and prevent condensation – the real equipment killer. DEC3 monitors internal temperature, humidity and lamp current at all times, and uses this information to control its lamp relay, fan(s) and heater(s). It can report back over the DMX cable, using the RDM protocol (Remote Device Management) if desired.

Unless otherwise specified, this version of the user guide refers to DEC3 units fitted with software version 2.1 or later.

### So, what does DEC3 actually DO?

DEC3 is the brains of the operation – here’s a layout:

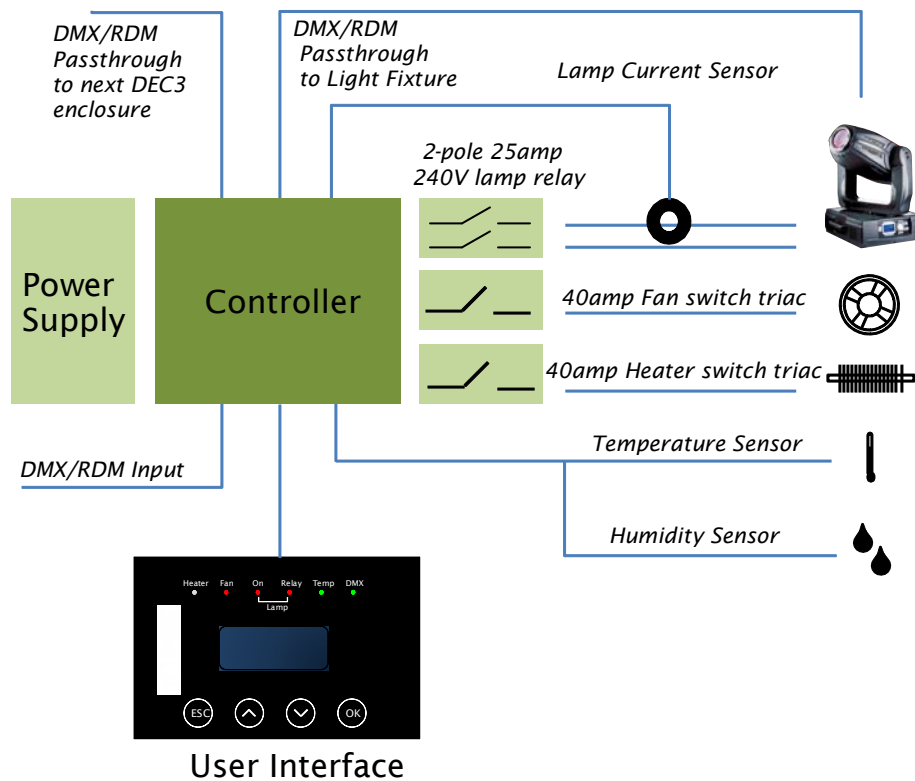

*This schematic shows the relationship between DEC3’s functional elements. The power supply is universal 90-260V, but fans and heaters are either 120V or 230VAC, and must be so specified. A high-quality 25amp 2-pole electro-mechanical relay isolates fixture/projector power in the event of an over-temperature condition. Fans and heaters are switched using generously overrated 40amp Triac devices for maximum reliability. Two DMX outputs connect to the internal fixture (if desired) and on to other enclosures or DMX devices.*

DEC3’s mission is to maintain temperature and humidity inside the enclosure, within determined bounds, and to prevent condensation – particularly overnight dew formation – inside the equipment housed. Condensation is fatal to electronic equipment, particularly in polluted areas or saline environments, where it brings not only rust and short-circuits, but also a steady buildup of mineral and/or salt deposits. Incidentally, condensation is very hard to control with air-conditioning type systems, which is why we don’t use them.

Broadly speaking, DEC3’s function depends on whether the fixture/projector lamp is on or off:

### **Lamp ON**

When the projector/fixture is running, the heat from the lamp takes care of humidity, and DEC3 runs the enclosure's fan(s) to change its air every few seconds – ensuring minimal temperature rise above outside ambient.

### **Lamp OFF**

When the lamp is off, DEC3 senses temperature and humidity and controls its fan(s) and heater(s) accordingly. When conditions are within normal bounds (between top and bottom temperature settings and below the humidity threshold (see below), DEC3 pulses the heater at a low level to dry the air and eliminate condensation, and runs the fans to change the enclosure air every 30 seconds or so. We call this 'pulse mode', and it is the key to preventing damaging condensation inside your equipment.

If the temperature rises above the top set limit (see below), DEC3 runs the fans to cool it down. In cold conditions, DEC3 will run the heater as required to maintain the bottom set temperature.

Thus, DEC3 maintains a comfortable operating temperature inside the enclosure, and prevents damage from condensation. Users all over the world have found that Tempest enclosures provide an optimal environment for expensive and delicate equipment, in every climate type.

And while doing all of this, DEC3 can tell you what's happening over your RDM network – a real boon in larger installations.

## *Operating Modes*

DEC3 may be run in one of three basic operating configurations. A fourth configuration is provided for test and service use.

**Standalone:** The enclosure operates independently, and automatically, requiring no user intervention. User may set parameters such as temperature and humidity thresholds, and monitor sensor information and DEC status at the DEC3 user interface. Standalone is the default DEC3 shipping mode unless specified otherwise at time of order. DMX is not required or utilized.

### **DMX/RDM Mode 1 (RDM Monitor)**

All of the Standalone features plus the ability to discover and monitor the DEC3 over a DMX512 connection, using RDM.

In this mode, the DEC3 does not need to “see” any DMX to operate. The mode allows the use of RDM to set the various temperature thresholds, and monitor the conditions inside the enclosure remotely. The fixture inside the Tempest enclosure may also be an RDM enabled device.

### **DMX/RDM Mode 2 (DMX Enable)**

All of the Standalone and RDM Monitor features plus the use of a single DMX address (slot) to control the Lamp Relay.

This means that the user is responsible for maintaining a DMX input with the slot (as selected as the DMX START ADDRESS on the DEC3) high. This slot level must be set greater than 50% at all times when the internal fixture is to be powered. This has the useful attribute of enabling the user to remotely force a hard reset of the fixture by opening and then closing the Lamp Relay. It also means that it is unnecessary to feed the enclosure with two power sources (for the enclosure and the luminaire/projector), since the DMX slot may be used to isolate the projector when not in use, without removing power from the enclosure. This mode is recommended for show-control applications, where it is desirable to have power control of the internal fixture, and accidental loss of the DMX data is very unlikely to occur.

In the absence of DMX, the Lamp Relay defaults to “ON”.

All RDM functions are available for configuration and monitoring of the DEC3.

### **DMX/RDM Mode 3 (Service/Test)**

This mode is intended for test and service use.

It gives the user direct control of the lamp, fan and heater relays over DMX. User may NOT override any of the relays in an unsafe direction – for example, if the DEC3 has determined the enclosure is over-temperature and has switched off the lamp relay, the relay may not be overridden ON by DMX. In this sense, DMX ‘piles

on' to DEC3 operation, within defined safety limits. However, until such time as the temperature reaches the TOP limit, the heater may be enabled and the fan disabled, which is why the mode should only be used for Test and Service use.

If the DEC3 has been purchased with DMX/RDM enabled, it is possible to select the required mode 1-3 using RDM. In the RDM context, this is known as selecting the device's DMX PERSONALITY. Setup of the DEC3 from the Front Panel is available in all configurations.



RDM is an effective and powerful tool for commissioning and monitoring an installation, particularly in large systems. For further guidance, we recommend you consult a qualified RDM system integrator. If you don't have one in your neighborhood, go to [www.tempestlighting.com](http://www.tempestlighting.com), and click on the RDM and RDM Integration bug on the home page for some useful contacts. Tempest Lighting warrants DEC3 to be compliant with the RDM standard, but is not an RDM systems integrator, and can offer only basic guidance on RDM utilization.

## *DEC3 Control Parameters*

DEC3 will run out of the box with its default parameter settings, which equate to the (fixed) settings of its predecessor DEC's 1 and 2.

Temperature:

Top Set	<i>Range 35-45°C, Default = 40°C</i> Most manufacturers recommend a max temperature for their equipment of 40°C, though this does vary. When DEC3 senses a temperature higher than Top Set, it indicates an overtemp condition as a warning. NOTE: in moving light enclosures the thermal sensor is necessarily placed in the exhaust air path, which will be higher (sometimes a lot higher) than the actual fixture ambient. This needs to be kept in mind when adjusting temperature settings.
Cutoff Temp	<i>Range 0-15°C, Default = 15°C</i> This is a setting <i>above</i> the Top Set temperature that determines the temperature at which the lamp relay is opened, cutting off power from the fixture/projector. The user may reduce it as desired, but should establish before doing so the actual operating temperatures experienced in hot weather before doing so, to avoid nuisance tripping.
Bottom Set	<i>Range 0-10°C, Default = 10°C</i> The temperature maintained by the heater in cold conditions. Most equipment manufacturers recommend a minimum

operating temperature of 0°C, and users may set it lower than the default if desired.

- Humidity      Range 50-90%, *Default 80%*  
The threshold at which incoming air is more aggressively heated to remove moisture. This parameter will not normally require adjustment.
- DMX Set      *Range 001-510, Default 001*  
Sets the DMX address for the lamp relay control. In the DMX/RDM service mode, the subsequent two DMX slots control fan and heater respectively.
- Lamp Hours    *Default 0000*  
DEC3 counts the hours your projector/fixture lamp is on, and can report it both on the user interface display and over RDM. ***Remember to reset to 0 when changing lamps.*** This is provided to allow lamp hours monitoring on devices such as Video Projectors and certain moving lights that have no native RDM or DMX support.

## Setup and Connections

### Operating Mode Setup

Your DEC3 will normally be factory set to the operating mode you specified in your order:

#### Operating Mode DIP Switch Settings

Mode	DIPswitch Settings	Mode Summary
Standalone	1-6 OFF	Standalone – no DMX/RDM
DMX/RDM	2 ON, 1, 3-6 OFF	DMX/RDM Modes 1-3 – support for remote monitoring

### DMX Connections

DMX refers to USITT DMX512, a commonly used control protocol in the entertainment industry, running over RS485. Consult USITT DMX installation guidelines when laying out a system, or employ a qualified DMX system integrator.

Note that DMX is optional – in many applications it is not required, and need not be connected.

**DMX IN** – Connect incoming DMX to the 2-part 3-pin terminal on the DEC3 control circuit board so labeled.

Pinout: (1) Ground, (2) Data -, (3) Data +.

**DMX THRU** – there are two DMX pass-through terminals – one for a fixture inside the enclosure, the other to run to the next DMX device in the network. Pinout: same as DMX IN.

### DMX Line Terminations

DMX cable runs must be terminated at the far end of the cable run with a termination resistor as detailed in the DMX standard. This is particularly important for satisfactory operation of DMX/RDM installations. The individual fixtures installed inside the Tempest enclosures must NOT be terminated. It is recommended that any line termination is done using the 3-pin terminal connector fitted to the DEC3 control circuit board.

1. Make sure that any DMX termination provided by the fixture inside your enclosure(s) is disabled.
2. The LAST enclosure in the installed DMX daisy chain should have a DMX Termination fitted to one of the pass through DMX connectors. Per the ANSI E1.11 standard, the Terminator shall be 120 ohm +5%/-10% impedance placed between Data+ and Data-. We recommend minimum power rating of 0.6W for the resistor.  
We recommend that the installer fit a label externally to say “DMX Termination fitted internally”.

Test:

3. Switch mains power OFF to all enclosures.
4. Before connecting the DMX line to your controller, measure the impedance between Pin 2 (Data-) and Pin 3(Data+) at the controller end. Reading should be around 100-130 ohms.

This test shows that you have a terminator in place, and also that you have continuity of Data- and Data+ between installed devices. If the measured resistance is significantly less than 100 ohms, (say 40-80 ohms) it suggests you may have multiple terminations in place. Check that any terminator switches on light fixtures are OFF. If impedance is very low, check for wiring shorts.

## *RDM Connections*

RDM refers to ANSI E1.20, a control protocol in the entertainment industry gaining popularity and essentially an “extension” of DMX512. The use of RDM is optional – but it does require a DMX512 cable connection.

## *Important – RDM and RDM Integration*

RDM (Remote Device Management) is an ANSI standard that adds bidirectional discovery and status monitoring to a standard DMX network connection. No additional wiring is required for RDM operation.

DEC3’s RDM implementation allows system integrators to set up remote control and status monitoring of all attributes and sensors, including:

- Temperature
- Humidity
- Lamp Current
- Elapsed Lamp Hours
- Lamp Relay Status
- Fan Relay Status
- Heater Relay Status
- DMX Status
- DMX Start Address
- DMX Personality (RDM Mode)
- Device Type
- Device Label
- Software Version

Tempest Lighting warrants that its RDM products are compliant to the RDM standard, but does not directly support RDM system integration. Tempest Lighting will however provide introductions to qualified RDM system integrators for customers requiring assistance in this area. Links are provided on the Tempest Lighting web site ([www.tempestlighting.com](http://www.tempestlighting.com)).

## Control Interface

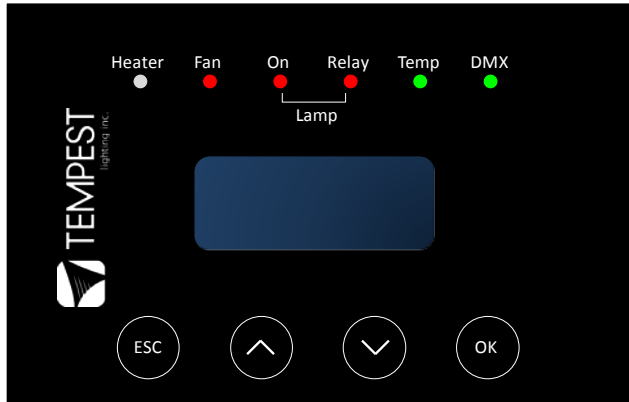

The control interface features a 2-line display, LED indicators, and 4 cap-sense control buttons.

### LED Indicators

#### Heater

SHORT PULSE (RED) - Indicates lamp is off, and the heater is pulsing to prevent condensation inside the enclosure and projector/light fixture. This is normal operation when the lamp is off and the temperature range is above the bottom set limit.

ON (RED) - Indicates heater is on, due to temperature being below bottom temperature setting when lamp is off.

OFF - indicates lamp is on and maintaining temperature above bottom limit.

#### Fan

SHORT PULSE (RED) - The fan is moving a little air through the enclosure, as part of the condensation prevention strategy. The fan comes on for a few seconds approximately every 30 seconds.

ON (RED) - Indicates fan is running, due to lamp being on or internal temperature exceeding top limit.

#### Lamp Relay

ON (RED) Indicates lamp relay closed and power is available to the internal fixture/projector.

OFF Indicates lamp relay open and power is removed from the internal fixture.

#### Lamp On

ON (RED) Indicates current sensed on the lamp circuit greater than 1 amp (this allows some current to be drawn for such things as fans and control electronics without the Lamp On indicator lighting. When the Lamp On indicator is on, the lamp counter is counting lamp life.

#### Temp

ON (GREEN) - The temperature is between Bottom and Top temperature settings.

FLASHING (RED) - The temperature is above Top setting but has not yet reached the Cutoff level.

ON (RED) - Temperature is above Cutoff level or below Bottom level.

DMX (only used when DMX/RDM setting is in effect)

ON (RED) - DMX error.

ON (GREEN) – Good DMX or RDM data packet received.

## Control Interface Operation

The Control Interface is normally LOCKED.

To UNLOCK, touch ESC and OK together for 5 seconds.

You are now in the CONTROL MENU

Use the arrow keys to scroll up and down the menu.

Use OK, to enter a menu item, then the arrow keys to set the item parameter, or to scroll to the next menu level.

Use ESC to back up a level, and OK to confirm settings.

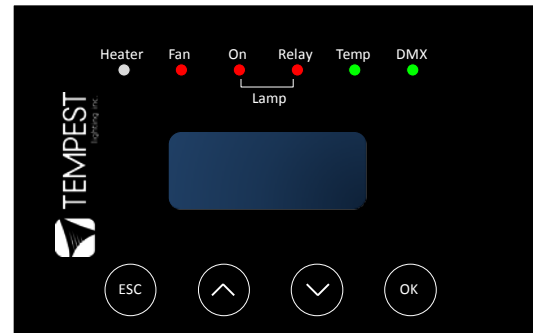

*Depending on the Operating Mode selected, and present status, DEC3's display shows you temperature, humidity, DMX address and a selection of error and status messages.*

### CONTROL MENU

#### DMX SET (if DMX/RDM mode 2 or 3 is selected)

Select a DMX starting address in the range 001 to 510

1 – Lamp Relay

In RDM Mode 3 an addition two slots are required

2 – Fan Relay

3 – Heater Relay

*Note that the DMX control is designed using a SAFETY pile-on Logic. In other words, the DMX input can only override automatic settings in a safe manner. For example, if the enclosure has switched off the lamp relay due to an over-temperature condition, the DMX input cannot switch it on, if the fans are running because of Overtemp, the DMX input cannot turn them off, and so on.*

*The DMX SET menu can be ignored if the DEC3 is in Standalone or DMX/RDM Mode 1 (RDM Monitor) mode.*

#### SET LAMP HOURS TO 0

The lamp hour counter needs to be reset each time you change the lamp in the fixture/projector. Make this a part of your maintenance instructions.

#### STATUS DISPLAY

View Temperature (in Celsius) and Relative Humidity (in %) inside the enclosure. Note that in Tornado moving light enclosures the temp/humidity sensor is located in the exhaust airflow, which may be significantly warmer than ambient.

#### HUMIDITY SET

The humidity level above which the heater kicks in to remove humidity from incoming air (default 80%, permissible range 50-90%). This setting should not normally be changed.

#### TEMP SET

Set three temperature trigger points for Top, Cutoff and Bottom temperatures.

##### TOP TEMP

The desired upper temperature limit for normal operation (default 40°C, permissible range 35-45°C).

When the DEC3 sees air above this temperature, but below the additional Cutoff temperature (see below), it indicates a temperature error. This is not dangerous, but may reduce lamp life.

#### **CUTOFF TEMP**

The desired upper temperature ABOVE the TOP TEMP setting, at which the lamp relay is forced to open, isolating the fixture/projector power.

(default 15°C, permissible range 0-15°C).

To avoid nuisance tripping, set this variable to the maximum, and monitor actual temperatures in your normal operating conditions. If your actual temperatures are running lower, then you may reduce the cutoff temperature margin. In hot climates, it may be advisable to set both TOP TEMP and CUTOFF TEMP as high as possible.

#### **BOTTOM TEMP**

The desired lower temperature limit for normal operation

(default 10°C, permissible range 0-10°C).

Note that a higher BOTTOM TEMP may provide additional protection against condensation in some conditions, but will consume more energy. Therefore a lower setting is desirable, provided the user is certain that no condensation is occurring.

#### **RDM MODE SET**

The RDM Mode is normally set using RDM commands from a remote RDM control device to set the DMX PERSONALITY of the DEC3.

From the DEC3 user interface, this menu item allows the user to check (and if necessary alter) the RDM mode. Please ensure that the DEC3 is NOT unintentionally left in Mode3 (Service/Test).

## 5 *Operation – Fan- Only Versions*

While there are no specific operational actions required for normal use, the following points should be kept in mind.

- ① **IF the fan and projector have been powered separately, it is the responsibility of the user to ensure that the fan is running at all times when the projector lamp is on.**
- ① Unless the enclosure or projector is undergoing routine maintenance, the enclosure should be closed and securely latched at all times.
- ① Only authorized personnel should open the enclosure (see maintenance warnings in the next chapter).
- ① **Do not routinely operate projector in full sun in hot weather. The enclosure has not been designed to protect the projector in this condition.**

## 6 *Mounting the Equipment in the Thunder Enclosure*

 If the Thunder enclosure is suspended from a ceiling or overhang, this must be done by two people.

1. Place the equipment on the equipment tray. If hanging the equipment upside-down, one person must hold the equipment in position, while another person secures it in place. Ensure that the equipment is securely held before proceeding further.



2. For most theatrical lights, adjust the yoke to the shortest available setting before installing in the enclosure, as shown here.
3. Move the Unistrut Channel nut into position, to line up with the fixture yoke.
4. Bolt through the yoke into the channel nut and tighten firmly in place, using the hardware provided.
5. Connect the equipment power cable to the equipment
6. Connect equipment control cables (if any)
7. Power up the equipment, check functions and adjust focus
8. Replace the enclosure cover
9. Make sure that all four latches are firmly fastened. The latches are adjustable, and should be checked periodically, since the rubber seal may compress slightly over time.
10. For additional security, use a bolt or padlock to lock one or more of the latches, using the security ring provided.



## 7 Operation – Fan- Only Enclosures

While there are no specific operational actions required for normal use, the following points should be kept in mind.

- ① **IF the fan and equipment have been powered separately, it is the responsibility of the user to ensure that the fan is running at all times when the equipment lamp is on.**
- ① Unless the enclosure or equipment is undergoing routine maintenance, the enclosure should be closed and securely latched at all times.
- ① Only authorized personnel should open the enclosure (see maintenance warnings in the next chapter).
- ① **Do not** routinely operate equipment in full sun in hot weather. The enclosure has not been designed to protect the equipment in this condition.





## 8 Routine Maintenance

It is very important to perform routine maintenance on both the enclosure and the equipment inside it. Failure to do so may reduce lifetime for both the enclosure and the equipment.

### Note

*Maintenance schedules depend on location and environment. The intervals given here are general minimum guidelines. It is up to the user to judge whether maintenance should be carried out more frequently. We recommend doing these tasks no less often than mentioned here.*

### Safety

-  As the enclosure is a powered unit with moving parts, it is necessary to keep safety in mind while performing routine maintenance. Although maintenance can be performed while the enclosure is powered, it is safer to carry it out with the power disconnected with proper lockout and tag out procedures followed.
-  Be aware that once the enclosure has had power applied to it, the fan will start to turn. Make sure that your hands are clear of the fan before applying power to the enclosure.
-  Only authorized personnel should perform maintenance on the enclosure or equipment
-  Do not service the unit in the rain or other adverse weather conditions (snow, sleet, high winds, etc.).

### Inspection Checklist: - Every Three (3) Months

- Glass should be clean and free of cracks
- Enclosure should be free of debris both inside and out
- Bolts and tie-down straps should be tight
- Door seals should be in good condition. Check seals inside and out for gaps.
- Fan should be functioning and not making excessive noise
- Intake filter should be clean

### Air Filter - Every Three (3) Months

The air filter from the intake vent on front of enclosure should be removed and cleaned on a regular basis. To remove filter, pull it directly out of the intake vent. The filter can be cleaned by running water from a hose and do not require any special solution.

To reinstall, push filter back into Velcro on the bottom of the intake vent. Filter should be flush with bottom of vent.



**Case - As Needed**

The outside of the case should be cleaned as needed. The case should be cleaned with a wet cloth and mild detergent (if necessary). Do not use a direct spray from a hose to clean the case.

**Window - As Needed**

Clean using a proprietary glass cleaning solution or a mild detergent, and wipe dry. Use only soft, lint-free cloths for glass cleaning. Never use an abrasive cleaner.

**Equipment**

Review the manufacturer's instructions for proper maintenance of your equipment/equipment. Remember, the enclosure simply protects the equipment inside it and is not a substitute for regular maintenance.

## 9 *Troubleshooting*

This is a guide to the general symptoms, problems, and solutions that may occur during the usage of your enclosure. However, it is important to remember that problems may occur within the equipment itself and these must also be considered.

### **Equipment does not have power.**

Check power supply wiring and voltage.

### **Fan is not spinning**

Fan cords may have become disconnected. Check connections between fan and cord.

Fan may be obstructed. Shut off power to enclosure and check for obstructions. Turn power back on to see if fan will start spinning. If fan does not turn then enclosure is not receiving power.

Turn off all power and check wiring. If the wiring is correct, contact technical support.

### **Equipment does not have power.**

Check equipment power switch. If switch is on, check wiring and supply switch/circuit breaker.

### **Equipment turns on and off repeatedly over short span of time.**

Check that vent areas and airways are clear. If so, ambient temperature may be too high, or equipment may have internal problem.

### **Excessive water in enclosure.**

Glass seal leak. Repair with silicone sealant.

Door gaskets leak caused by separation. Silicone piece back into place or replace section.

## 10 Limited Warranty

### What is covered. Exclusions.

Unless otherwise stated, your product is covered by a one (1) year parts and labor limited warranty. Factory-painted product is not guaranteed against scratches. It is the Owner's responsibility to furnish receipts or invoices for verification of purchase date, and dealer or distributor. If purchase date cannot be provided, date of manufacture will be used to determine start of warranty period. Unless otherwise specifically stated in writing, all warranty work is carried out at the Tempest Lighting factory. In the event that the Owner purchases any optionally available on-site check-out or turn-on services, Owner agrees to provide facilities to perform such services at ground level. Tempest Lighting does not in any way offer any warranty for the equipment.

### Owner Responsibility for Installation.

Tempest Lighting makes no recommendations for mounting any Tempest Lighting product. It is the sole responsibility of the Owner to perform any necessary structural, electrical, environmental or other appropriate analysis prior to installing any Tempest Lighting product.

### Returning an Item Under Warranty for Repair.

It is necessary to obtain a Return Material Authorization number (RMA#) from your dealer or point of purchase, BEFORE any units are returned for repair. The manufacturer will make the final determination as to whether or not the unit is covered by warranty.

Any Product unit or parts returned to Tempest Lighting, Inc., must be packaged in a suitable manner to ensure the protection of such Product unit or parts, and such package shall be clearly and prominently marked to indicate that the package contains returned Product units or parts and with a Return Material Authorization (RMA#) number. Accompany all returned Product units or parts with a written explanation of the problem or malfunction.

**NOTE:** *Freight Damage Claims are invalid for equipments shipped in non-factory boxes and packing materials. These materials can be supplied if requested, at additional cost. It is recommended that all packaging material be retained for possible re-use.*

### Freight.

All shipping charges must be prepaid by the Owner. Items under warranty shall have return shipping paid by the manufacturer only in the Continental United States. Under no circumstances will freight collect shipments be accepted. Prepaid return shipping does not include expediting such as airfreight. Airfreight will ship customer collect.

REPAIR OR REPLACEMENT AS PROVIDED FOR UNDER THIS WARRANTY IS THE EXCLUSIVE REMEDY OF THE CONSUMER. TEMPEST LIGHTING, INC. MAKES NO WARRANTIES, EXPRESS OR IMPLIED, WITH RESPECT TO ANY PRODUCT, AND TEMPEST LIGHTING SPECIFICALLY DISCLAIMS ANY WARRANTY OF MERCHANTABILITY OR FITNESS FOR A PARTICULAR PURPOSE. TEMPEST LIGHTING SHALL NOT BE LIABLE FOR ANY INDIRECT, INCIDENTAL OR CONSEQUENTIAL DAMAGE, INCLUDING LOST PROFITS, SUSTAINED OR INCURRED IN CONNECTION WITH ANY PRODUCT OR CAUSED BY PRODUCT DEFECTS OR THE PARTIAL OR TOTAL FAILURE OF ANY PRODUCT REGARDLESS OF THE FORM OF ACTION, WHETHER IN CONTRACT, TORT (INCLUDING NEGLIGENCE), STRICT LIABILITY OR OTHERWISE, AND WHETHER OR NOT SUCH DAMAGES WERE FORESEEN OF UNFORESEEN.

Warranty is void if the product is misused, damage, modified in any way, or where unauthorized repairs or parts have been employed. This warranty gives you specific legal rights, and you may also have other rights, which vary from state to state.

### Tempest Product Support.

Step 1: First contact your local Dealer for support. Your dealer is best placed to respond quickly to your needs.

Step 2: If your dealer is unable to answer your questions please contact our Sales Office:

Tempest Lighting, Inc.  
13110 Saticoy Street, Unit C  
North Hollywood, CA 91605, USA  
Tel +1 818 787 8984  
Fax +1 818 982 5582  
[support@tempestlighting.com](mailto:support@tempestlighting.com)

Visit our web site for current information and specifications:

[www.tempestlighting.com](http://www.tempestlighting.com)

## ***11 Registration***

Filling out the registration form on the next page and sending it to the Tempest Lighting factory within 30 days of installation entitles you to the warranty cover specified in this manual. It also enables us to notify you in case of important news or post-sale information regarding the Thunder Lighting Enclosure.

## ***Thunder Enclosure Registration Form***

Detach and mail/fax to:

Tempest Lighting, Inc., 13110 Saticoy St., N Hollywood, CA 91605

Fax # +1 818 787 4994

If a Tempest Representative has not inspected the installation, please send photos showing installation.

Model Number: .....

Serial Number: .....

Latch Key Number: .....

Dealer/Sold By

Name: .....

Location: .....

Date Purchased: .....

Contractor/Installed By

Name: .....

Date Installed: .....

Location Installed: .....

Company/Organization

Name: .....

Street Address:

.....

City, State, ZIP, Country:

.....

Phone: .....

Fax: .....

Contact Information

Name: .....

Phone: ..... Extension: .....

Fax: .....

E-mail: .....