

User Manual and Installation Guide

Tornado Moving Light Enclosures

Outdoor Protection for your Indoor Equipment



You can download a copy of this manual at
<http://www.tempestlighting.com/products.html#tornado>

***This manual applies to product manufactured after June 30th, 2010
with DEC3 firmware revision 2.1 or higher***

Tempest Lighting, Inc.
13110 Saticoy Street, Unit C
N. Hollywood, CA 91605, USA

Tel +1 818 787 8984
Fax +1 818 982 5510
info@tempestlighting.com

Tornado 2050
Tornado 2000
Tornado 2200
Tornado 2300
Tornado 2400

August, 2010

In the interest of continuous product improvement, the information in this document is subject to change without notice. Neither Tempest Lighting, Inc. nor its representatives or agents may be held liable for expense or injury arising from it.

Table of Contents

Topic	Section
Introduction.....	1
Identifying Major Parts.....	1.1
INSTALLATION.....	2
Safety and Warnings.....	2.1
Handling the Enclosure.....	2.2
Preparation.....	2.3
Mounting the Enclosure.....	2.4
Guidelines for Mounting Plates.....	2.5
Installing at varying angles.....	2.6
Wiring – Power Connections.....	3
DMX Connections.....	3.1
DEC3 Control System.....	4
Mounting the Luminaire – Tornado 2000, 2200, 2300.....	5
Mounting the Luminaire – Tornado 2050.....	5.1
Mounting the Luminaire – Tornado 2400.....	5.2
Closing the Enclosure.....	5.3
Activation and Checkout.....	6
Operation.....	7
Routine Maintenance.....	8
Troubleshooting.....	9
Sample Specification Boilerplate.....	10
Warranty.....	11
Registration.....	12



Declaration of Conformity

This is to certify that the following products

- Tornado 2000.IN Lighting Enclosure**
- Tornado 2200.IN Lighting Enclosure**
- Tornado 2300.IN Lighting Enclosure**
- Tornado 2300.IN Lighting Enclosure**

are in Compliance with the following standards or specifications according to the EMC Directive 89/336/EEC.

EN55015, EN61000-3-4, EN61000-3-5, EN61000-4-2, EN61000-4-3, EN61000-4-4, pr EN61000-4-5, EN61000-4-6, EN61000-4-8, EN61000-4-11

and are in compliance with the following standards or specifications according to the Low Voltage Directive 73/23/EEC.

EN60598-1

This declaration is made by the manufacturer

**Tempest Lighting, Inc.
5401 Bevis Avenue
Sherman Oaks, CA 91411, USA**

This declaration is based on tests that were conducted on the submitted samples of the above mentioned products. Detailed results can be referred to test reports CET.TE200909 and LVT.Te200909.

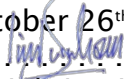
Dated: October 26th, 2009
Signature 
Tempest Lighting Inc





Declaration of Conformity

This is to certify that the following product:

Tornado 2400.IN Lighting Enclosure

is in Compliance with the following standards or specifications according to the EMC Directive 89/336/EEC.

EN55015, EN61000-3-4, EN61000-3-5, EN61000-4-2, EN61000-4-3, EN61000-4-4, pr EN61000-4-5, EN61000-4-6, EN61000-4-8, EN61000-4-11

and are in compliance with the following standards or specifications according to the Low Voltage Directive 73/23/EEC.

EN60598-1

This declaration is made by the manufacturer

**Tempest Lighting, Inc.
5401 Bevis Avenue
Sherman Oaks, CA 91411, USA**

This declaration is based on tests that were conducted on the submitted samples of the above mentioned products. Detailed results can be referred to test reports CET.TE200909 and LVT.Te200909.

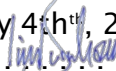
Dated: May 4th, 2010
Signature 
Tempest Lighting Inc



Declaration of Conformity

This is to certify that the following product:

Tornado 2050.IN Lighting Enclosure

is in Compliance with the following standards or specifications according to the EMC Directive 89/336/EEC.

EN55015, EN61000-3-4, EN61000-3-5, EN61000-4-2, EN61000-4-3, EN61000-4-4, pr EN61000-4-5, EN61000-4-6, EN61000-4-8, EN61000-4-11

and are in compliance with the following standards or specifications according to the Low Voltage Directive 73/23/EEC.

EN60598-1

This declaration is made by the manufacturer

**Tempest Lighting, Inc.
5401 Bevis Avenue
Sherman Oaks, CA 91411, USA**

This declaration is based on tests that were conducted on the submitted samples of the above mentioned products. Detailed results can be referred to test reports CET.TE200909 and LVT.Te200909.

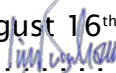
Dated: August 16th, 2010
Signature 
Tempest Lighting Inc

1 Introduction

The Tornado™ Lighting Enclosure

Thank you for purchasing the Tornado Lighting Enclosure. We hope that your new acquisition will soon be enhancing the environment around you through the magic of intelligent lighting. Although originally intended for outdoor environments, the design of the Tornado is such that it can satisfy many other needs. Not only will it protect against hostile outdoor conditions, but also against particulate, smoke, and other indoor conditions that can shorten the life of your lighting products. The Tornado is appropriate where there is a need for both intelligent lighting and enhanced aesthetics, such as an office building atrium, church, or multi-function hall. Compactly shaped and available in many colors, this enclosure always looks in place. The Tornado combines form, function, and intelligent lighting to provide you with almost limitless possibilities.

Using This Manual

Please read this manual in its entirety before starting work. All the information contained is important, and should be read carefully before proceeding. Heed all warnings and advisories.

Terminology:

Enclosure - Tornado Lighting Enclosure

Luminaire - intelligent lighting fixture that will be placed into the enclosure

DMX - ANSI E1.11-2008, Entertainment Technology - USITT DMX512-A, Asynchronous Serial Digital Data Transmission Standard for Controlling Lighting Equipment and Accessories.

RDM - ANSI E1.20-2006, Entertainment Technology - RDM, Remote Device Management over DMX512 Networks

Icon Key:

① Valuable information

⚡ Electrical Warning

🚧 Safety Information

IMPORTANT SAFETY NOTICE: All safety instructions provided by the luminaire manufacturer must be followed carefully. Failure to do this may void both the luminaire and the enclosure warranties.

When working at heights or in awkward locations, it is imperative to develop a safety plan, based on the information in this manual, and on local conditions and safety regulations. The safety plan must be approved by the site engineer/safety officer, as appropriate to local conditions. NEVER attempt to install Tornado enclosures in high winds or when precipitation is present or imminent.

Dimensions

Tornado 2000 (Base Down)

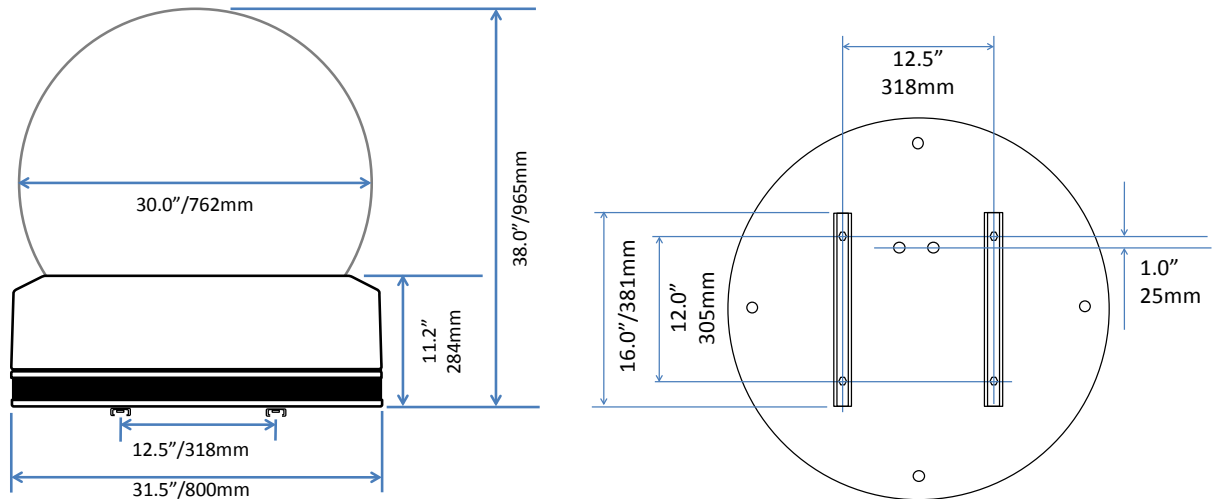

Tornado 2200, 2300 (Base Down)

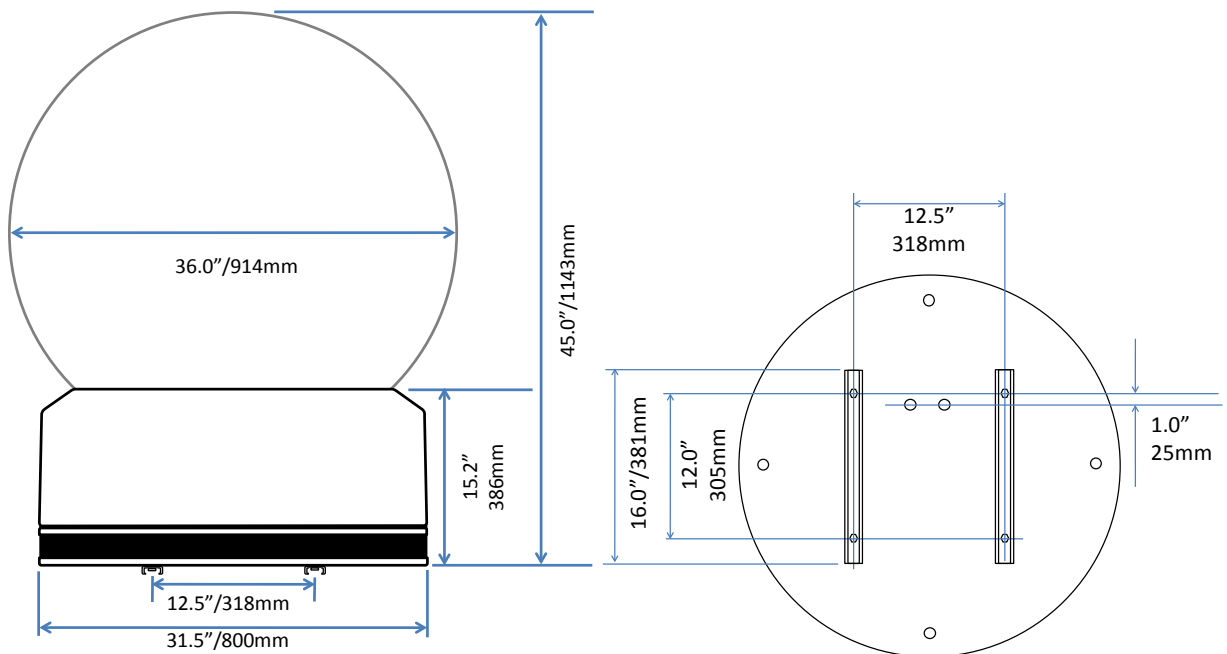

IMPORTANT: see additional dimensions for Base-up and Horizontal configurations on page 13

Dimensions

Tornado 2400 (Base Up or Down)

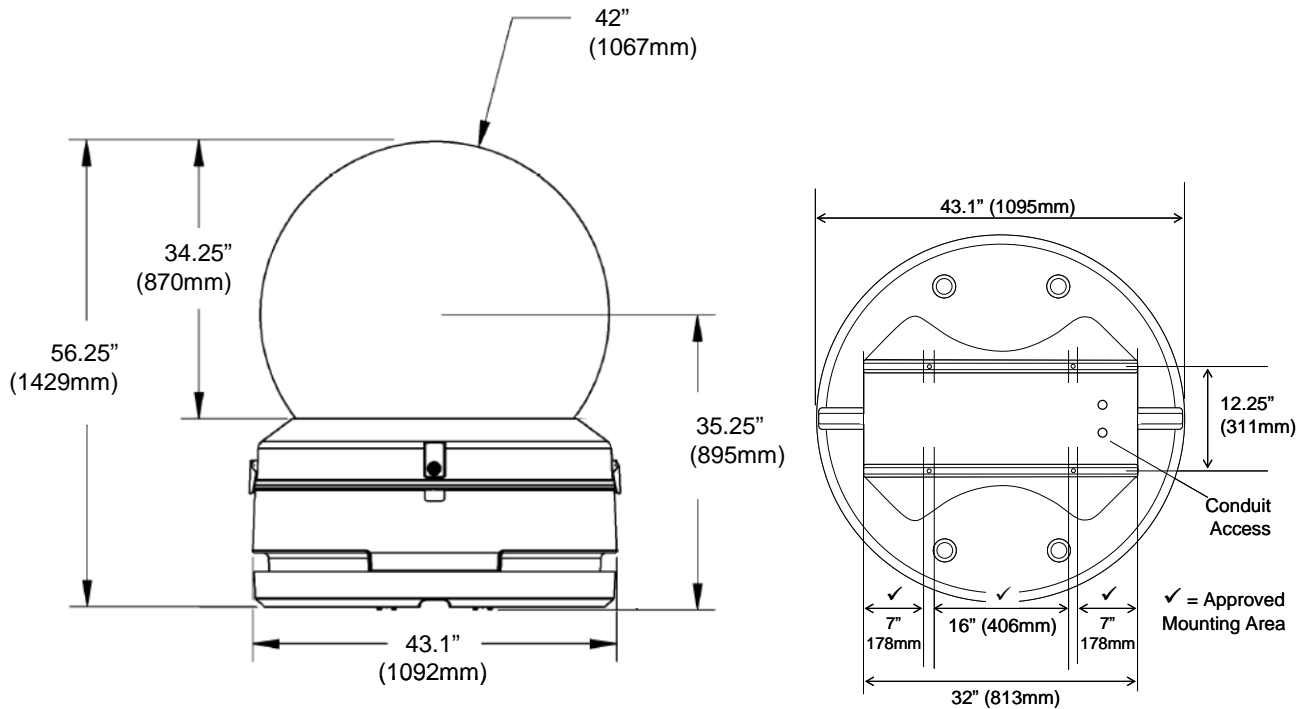



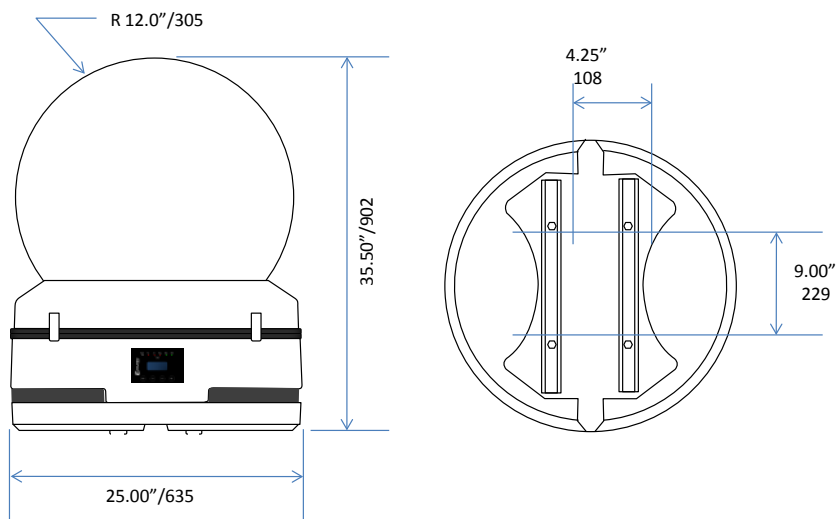





Tornado 2050 (Base Up, Down or Horizontal)



2 Installation



2.1 Safety and Warnings

These warnings are for your protection. Failure to comply may result in serious injury or death. Manufacturer assumes no responsibility for damages or injury incurred by misuse or mishandling of product.

-  **Do not** attempt to install or operate the enclosure before fully reading and understanding this manual
-  **Never** allow anyone who has not read this manual to open the enclosure or perform maintenance on the luminaire within.
-  **Never** leave the enclosure unattended when open.
-  **Always** make sure all bolts are tight and safety cables are in place after performing any form of maintenance on the unit.
-  Even after power has been disconnected from the unit, it is likely that the heater will remain warm. **Do not** touch it unless you can be sure that the heater has been off for at least one hour.
-  **Observe** all posted warnings in the enclosure itself.
-  **Do not** open any electrical boxes until power has been shut off to all supply lines to the enclosure (including the one powering the luminaire).
-  **Do not** open the enclosure in wet weather.

2.2 Handling the Enclosure

In order to preserve the integrity of the Tempest Enclosure, care must be taken to prevent damage. Following these simple guidelines will ensure that damage is not incurred in normal conditions.

-  **Never** move the enclosure with the luminaire inside.
-  **Never** handle the enclosure by the globe.
-  **Always** lift from under the base.

2.3 Preparation

Before starting the installation of the Tempest Enclosure, you must prepare the location, the luminaire and the enclosure itself.

Planning

Before beginning, it is necessary to decide how the enclosure will be mounted. These considerations must be taken into account.

- ① No part of the enclosure should fall below two feet above the average snowfall for the area. If snow is not a consideration, then enclosure may sit on ground as long as proper drainage is available.
- ① Enclosure will need to be powered at all times, although fixture may not be.

Tools and Equipment

To install the enclosure, you will need the following items:

- 👥 Two people to carry out the installation. **Warning:** This installation cannot be safely completed by 1 person.
- ① Crescent wrench
- ① Phillips screwdriver
- ① Proper wiring installation equipment (for line power and DMX)
- ① Any equipment listed in the fixture manufacturer's fixture-specific installation directions

2.4 Mounting the Tornado Enclosure

The Tornado enclosure is provided with two parallel lengths of 1 5/8" x 13/16" Unistrut mounting channel on the base of the enclosure. The four bolts/washers/channel nuts used to secure the Tornado to its pallet for shipping are stainless steel, and should be retained for mounting purposes.

- ① **Tempest Lighting supplies and recommends the use of stainless steel mounting hardware.**
- ① Since the Unistrut channels provided are themselves fixed to the enclosure body with bolts that obstruct the channel, each Tornado model has an 'Approved Mounting Area' defined within the Unistrut channels. All external fixings must be made within the approved mounting area.

Use the Bolts supplied to mount the Tornado to a mounting plate (see below for dimensions), or order four of the pipe-mounting kits for each Tornado, to mount to a pipe or truss. For stability, four mounting positions must be used.

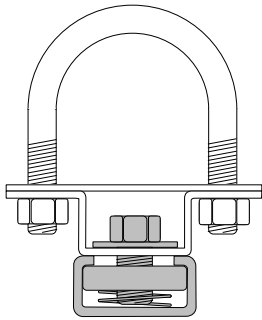

4900.MCT Pipe clamp, for pipes 1.5" (38mm) to 2" (50mm) OD. Four required per enclosure.

4925.MCT Pipe clamp, for pipes 2" (50mm) to 2.5"/64mm OD. Four required per enclosure.

Note that the parts shown shaded in gray are supplied with the Tornado enclosure.

Tornado enclosures will typically be mounted either onto a base plate, fabricated by others, using the 4900.MB mounting kit, or onto a truss or pipe structure, using the 4900.MC kit. In either case, four kits are required.

2.5 Guidelines for mounting plates

These guidelines are intended for use by customers mounting Tornado enclosures onto a custom superstructure.

Mounting plates should be made from 1/4" (6mm) or greater aluminum or stainless steel plate. DO NOT USE PLYWOOD or similar materials in outside locations. The following diagrams show the recommended size and hole patterns required for each Tornado model.

IMPORTANT: The conduit access points on the base of the enclosure required for connection to power and control signals must not be obstructed.

Tornado 2050 Recommended Mounting Plate

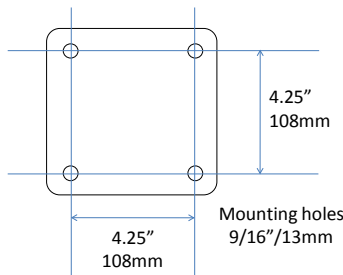

Tornado 2000, 2200, 2300 Recommended Mounting Plate

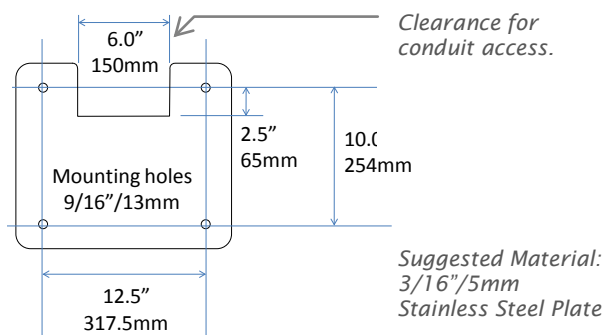

Tornado 2400 Recommended Mounting Plate

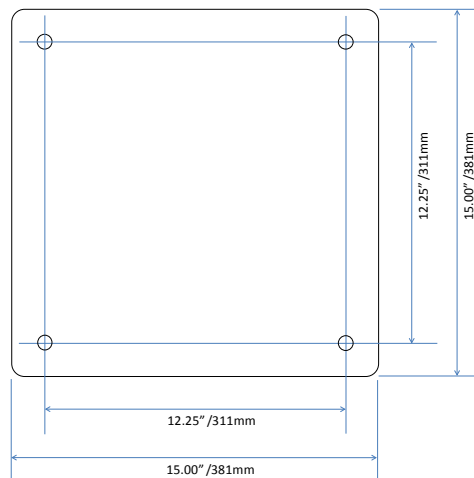

*Suggested Material:
3/16"/5mm
Stainless Steel Plate*

2.6 Installing Tornado 2000, 2200 and 2300 Enclosures at Varying Angles

Note:

Tornado 2050 may be installed in any orientation.

Tornado 2400 may be installed either base up or base down.

Standard Tornado 2000, 2200 and 2300 enclosures are now designed to be operated in a base down (globe up) orientation, and will be so supplied unless instructed otherwise. Variants are now available optimized for base up (globe down) and Horizontal installation, and are identified with the suffix V and H on the part number, respectively, eg

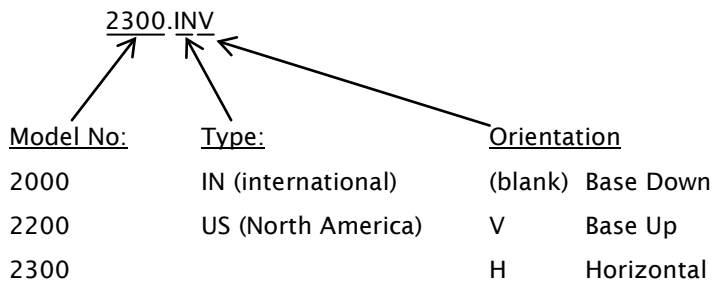

For base up/globe down or horizontal operation, a small drainage hole (weep hole) will be drilled in the globe, to permit any water draining through the enclosure to exit harmlessly. This will normally be done at the factory, but if done on site, ***IT IS ESSENTIAL TO USE THE APPROPRIATE TAPERED DRILL BIT, OBTAINABLE FREE OF CHARGE FROM TEMPEST LIGHTING. DRILLING WITH A STANDARD BIT MAY SHATTER THE PLEXIGLASS GLOBE. TEMPEST LIGHTING WILL NOT BE RESPONSIBLE FOR DAMAGE CAUSED BY FAILING TO HEED THIS WARNING.***

Weep holes do not affect the performance of the enclosure and are necessary to prevent water buildup inside the enclosure.

Base Down and Base Up Mounting

Tornado 2000, 2200 and 2300 enclosures for Base Up mounting (identified by part number suffix V – eg 2000.USV) are supplied with wraparound rain protection, on an enlarged base panel (see dimension below). This prevents rain entering into the air intake vents.

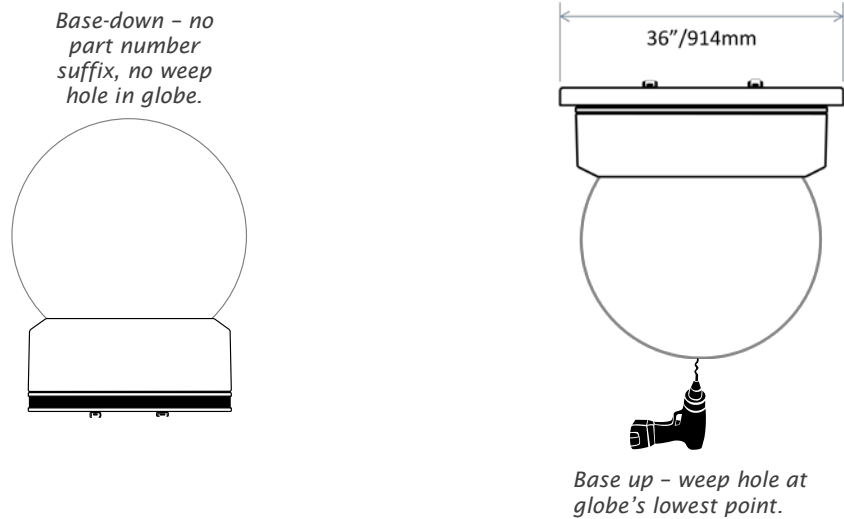

Horizontal Mounting

Tornado 2000, 2200 and 2300 enclosures for horizontal mounting (identified by part number suffix H – eg 2300.INH) are supplied with wraparound rain protection, on an enlarged base panel (see dimension below). This prevents rain entering into the air intake vents. Note that the weep hole will normally be drilled at the Tempest factory, and the correct globe orientation, with the weep hole at the bottom, is indicated by a yellow dot.

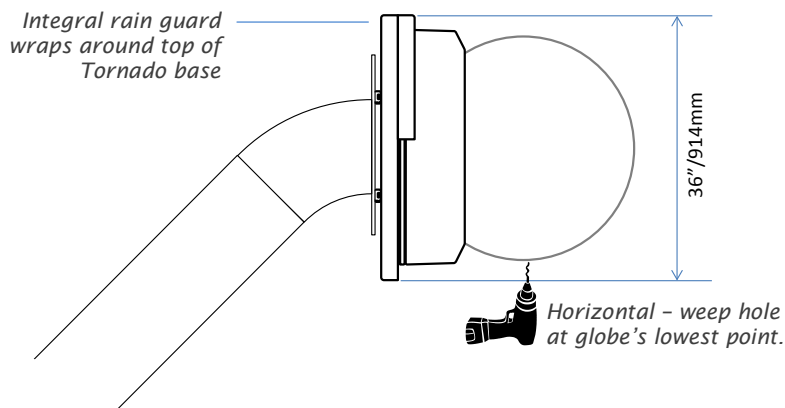

Note: When removing the globe on a horizontally mounted Tornado enclosure, take care to replace the globe with the weep hole at the lowest point.

Installation above public Spaces

If the Tornado enclosure is to be installed above an area accessible to the public (eg a street or an auditorium), some jurisdictions require a safety bond to be installed.

A stainless steel eyebolt is included with base-up and horizontal versions, and should be installed as follows:

1. Remove one of the four bolts holding the Unistrut onto the enclosure base
2. Replace it with the eye bolt, washer and nut supplied, and screw down tight

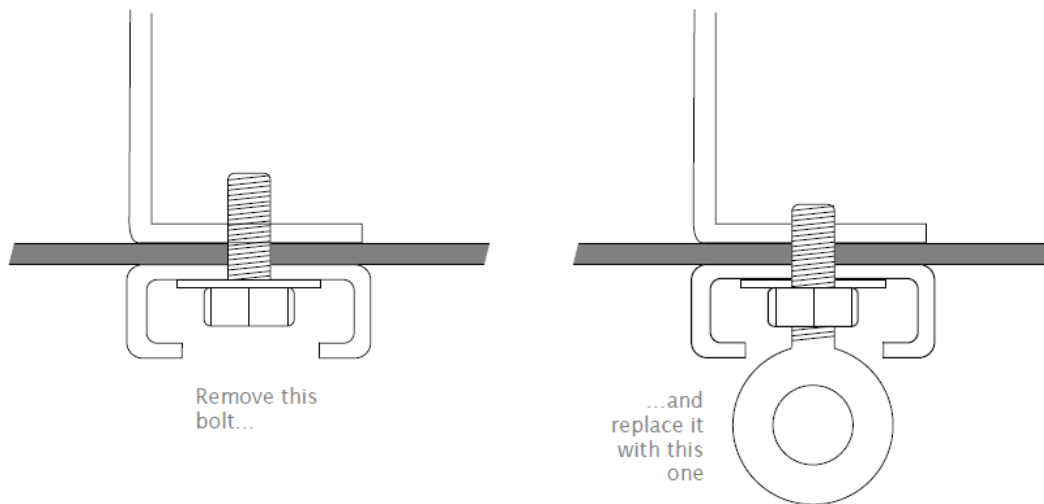

Safety Bond

Use a suitably-rated steel wire rope, threaded through the eyebolt, and attach securely to a structural member, in accordance with local safety regulations.



3 Wiring

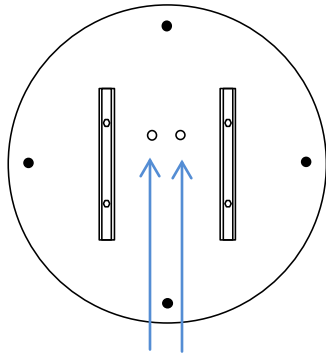

Power and DMX conduit entries

There are two wiring entry holes on the underside of the Tornado enclosure, one for power and one for DMX signal cable(s). Power and signal cables must be routed separately to the enclosure.

The conduit entry holes are 0.875" (22.2mm), and will accept US 1/2" conduit fittings, and international 20mm (OD) conduit fittings.

It will generally be most convenient to connect flexible conduit from the enclosure to adjacent electrical boxes. *Note: In any conflict between this manual and local electrical standards, local standards must prevail.*

Electrical Preparation

This covers the permanent location where the enclosure will be mounted.

⚡ **All electrical work must be carried out by a properly licensed electrician. Failure to observe this point will void the factory warranty for the Tempest Enclosure and possibly the luminaire.**

- 1 Before starting work, switch off power to the branch circuit, carefully following lockout and tag-out procedures. Failure to do so could cause serious injury or death.
- 2 You will need two electrical junction boxes, located within a few feet of the enclosures. Both junction boxes must be installed in accordance with local electrical codes (one for power, one for DMX control). Each junction box should have a length of 1/2" (International - 20mm OD) flexible weather-resistant conduit long enough to reach from junction box to the enclosure conduit bodies. Make sure to leave slack for positioning of enclosure.

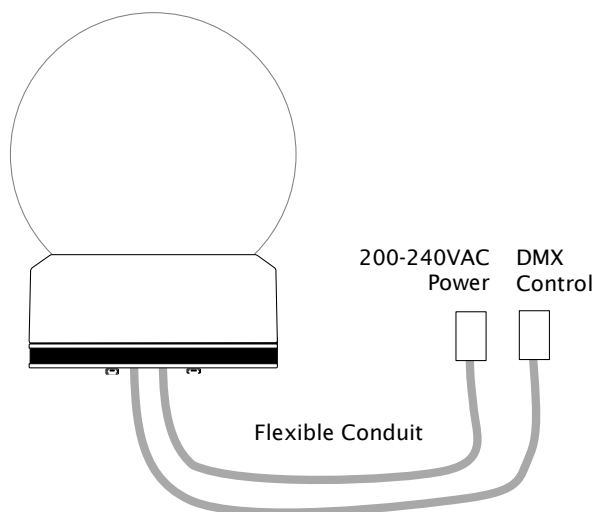

- 3 The DMX junction box should contain the DMX cable(s) that will connect to the enclosure (if required) and luminaire. See the DEC3 section below for DMX wiring instructions.
- 4 The power junction box should contain the 200-240VAC (50/60Hz) power supply line(s) for

both the enclosure and luminaire. Depending on your luminaire and requirements, you may choose a single line or two separate lines. Since the enclosure needs to be powered at all times, the only way to use a single line is if you will be using the DEC3 controller in DMX mode, to switch the enclosure's lamp relay on and off with DMX (see the DEC3 Control section of this manual). If the luminaire must be switched on and off by switching the luminaire supply on and off, two separate supply lines will be required. The supply line(s) will run through the flexible conduit into the enclosure's power conduit body.

Enclosure Supply Voltage

Tornado enclosures normally operate on a supply voltage between 208-24VAC. In certain circumstances they may be supplied for 120VAC operation. The following instructions assume 208-240VAC – if connecting the enclosure to a 120VAC supply, be sure to double the current stipulated for 240V.

Tempest enclosures may be wired on single or double line supplies. On a single feed, both enclosure and luminaire are permanently on. With a double-line supply, you can switch off the luminaire when not in use, while the enclosure continues to protect it 24/7.

Either way, the enclosure must be powered 24/7, in order to protect the luminaire inside against condensation and extremes of temperature.

- 5 **Single-line requirements.** This line must be capable of carrying 240VAC @ 5A plus the current required by the luminaire (over the requisite distance). Note that this also requires that the luminaire operate on 240VAC power.
- 6 **Double-line requirements.** In this case, there will be two lines, an enclosure supply line and a luminaire supply line. This requires that the enclosure line be capable of carrying 240VAC @ 5A and the luminaire line be capable of carrying the current required by the luminaire (over the requisite distance).

AC Connections

① Remember that the enclosure will need to be powered at all times, even though the fixture may not be. For more information on this and power supply lines, read Step 4 of Location Preparation.

⚡ **Line connections must only be carried out by a licensed electrician.**

- 1 Before beginning to connect the power supply line(s), turn on the circuits to be used and measure the voltages present. Make sure that the enclosure circuit provides 200-240VAC and that the luminaire circuit, if different from the enclosure circuit, provides the proper voltage for the luminaire.

⚡ After doing this, turn off all circuits that are being used and use proper lockout and tag-out procedures. The power supply lines run through the conduit fitting into the power supply conduit body (containing power wires) and connections can then be made.

3.1 DMX Connections

DMX refers to USITT DMX512, a commonly used control protocol in the entertainment industry, running over RS485. Consult USITT DMX installation guidelines when laying out a system, or consult a qualified DMX system integrator.

Note that DMX is optional - in many applications it is not required, and need not be connected. For more information, see DEC3 Operating Modes in the next section.

DMX IN - Connect incoming DMX to the 2-part 3-pin terminal on the DEC3 control circuit board so labeled.

Pinout: (1) Ground, (2) Data -, (3) Data +.

DMX THRU - there are two DMX pass-through terminals - one for a fixture inside the enclosure, the other to run to the next DMX device in the network.

Pinout: (1) Ground, (2) Data -, (3) Data +.

DEC3 Control – Introduction

Tempest Lighting and Projector Enclosures have been in daily use around the world for almost a decade. Tempest enclosures protect expensive and delicate equipment in all climates, maintaining a comfortable operating temperature, and preventing condensation – the real outdoor enemy.

DEC3™ – that’s *Digital Enclosure Control, third Generation* – is the brain of your Tempest enclosure. It will maintain the internal environment in a comfortable temperature and humidity range, and prevent condensation – the real equipment killer. DEC3 monitors internal temperature, humidity and lamp current at all times, and uses this information to control its lamp relay, fan(s) and heater(s). It can report back over the DMX cable, using the RDM protocol (Remote Device Management) if desired.

Unless otherwise specified, this version of the user guide refers to DEC3 units fitted with software version 2.1 or later.

So, what does DEC3 actually DO?

DEC3 is the brains of the operation – here’s a layout:

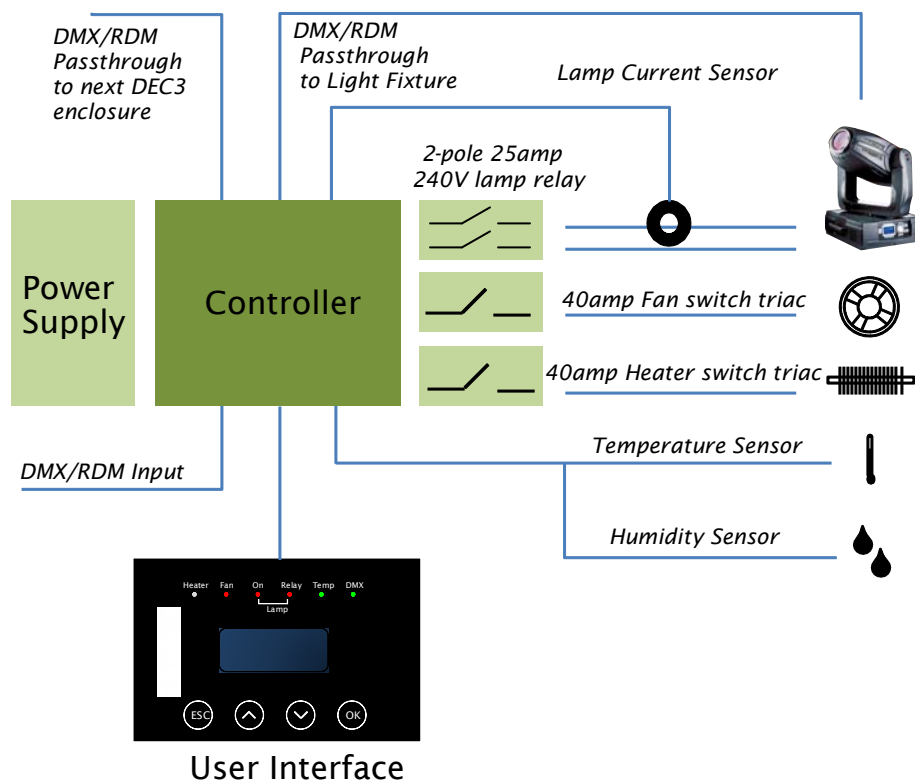

This schematic shows the relationship between DEC3’s functional elements. The power supply is universal 90-260V, but fans and heaters are either 120V or 230VAC, and must be so specified. A high-quality 25amp 2-pole electro-mechanical relay isolates fixture/projector power in the event of an over-temperature condition. Fans and heaters are switched using generously overrated 40amp Triac devices for maximum reliability. Two DMX outputs connect to the internal fixture (if desired) and on to other enclosures or DMX devices.

DEC3’s mission is to maintain temperature and humidity inside the enclosure, within determined bounds, and to prevent condensation – particularly overnight dew formation – inside the equipment housed. Condensation is fatal to electronic equipment, particularly in polluted areas or saline environments, where it brings not only rust and short-circuits, but also a steady buildup of mineral and/or salt deposits. Incidentally, condensation is very hard to control with air-conditioning type systems, which is why we don’t use them.

Broadly speaking, DEC3's function depends on whether the fixture/projector lamp is on or off:

Lamp ON

When the projector/fixture is running, the heat from the lamp takes care of humidity, and DEC3 runs the enclosure's fan(s) to change its air every few seconds – ensuring minimal temperature rise above outside ambient.

Lamp OFF

When the lamp is off, DEC3 senses temperature and humidity and controls its fan(s) and heater(s) accordingly. When conditions are within normal bounds (between top and bottom temperature settings and below the humidity threshold (see below), DEC3 pulses the heater at a low level to dry the air and eliminate condensation, and runs the fans to change the enclosure air every 30 seconds or so. We call this 'pulse mode', and it is the key to preventing damaging condensation inside your equipment.

If the temperature rises above the top set limit (see below), DEC3 runs the fans to cool it down. In cold conditions, DEC3 will run the heater as required to maintain the bottom set temperature.

Thus, DEC3 maintains a comfortable operating temperature inside the enclosure, and prevents damage from condensation. Users all over the world have found that Tempest enclosures provide an optimal environment for expensive and delicate equipment, in every climate type.

And while doing all of this, DEC3 can tell you what's happening over your RDM network – a real boon in larger installations.

Operating Modes

DEC3 may be run in one of three basic operating configurations. A fourth configuration is provided for test and service use.

Standalone: The enclosure operates independently, and automatically, requiring no user intervention. User may set parameters such as temperature and humidity thresholds, and monitor sensor information and DEC status at the DEC3 user interface. Standalone is the default DEC3 shipping mode unless specified otherwise at time of order. DMX is not required or utilized.

DMX/RDM Mode 1 (RDM Monitor)

All of the Standalone features plus the ability to discover and monitor the DEC3 over a DMX512 connection, using RDM.

In this mode, the DEC3 does not need to “see” any DMX to operate. The mode allows the use of RDM to set the various temperature thresholds, and monitor the conditions inside the enclosure remotely. The fixture inside the Tempest enclosure may also be an RDM enabled device.

DMX/RDM Mode 2 (DMX Enable)

All of the Standalone and RDM Monitor features plus the use of a single DMX address (slot) to control the Lamp Relay.

This means that the user is responsible for maintaining a DMX input with the slot (as selected as the DMX START ADDRESS on the DEC3) high. This slot level must be set greater than 50% at all times when the internal fixture is to be powered. This has the useful attribute of enabling the user to remotely force a hard reset of the fixture by opening and then closing the Lamp Relay. It also means that it is unnecessary to feed the enclosure with two power sources (for the enclosure and the luminaire/projector), since the DMX slot may be used to isolate the projector when not in use, without removing power from the enclosure. This mode is recommended for show-control applications, where it is desirable to have power control of the internal fixture, and accidental loss of the DMX data is very unlikely to occur.

In the absence of DMX, the Lamp Relay defaults to “ON”.

All RDM functions are available for configuration and monitoring of the DEC3.

DMX/RDM Mode 3 (Service/Test)

This mode is intended for test and service use.

It gives the user direct control of the lamp, fan and heater relays over DMX. User may NOT override any of the relays in an unsafe direction – for example, if the DEC3 has determined the enclosure is over-temperature and has switched off the lamp relay, the relay may not be overridden ON by DMX. In this sense, DMX ‘piles

on' to DEC3 operation, within defined safety limits. However, until such time as the temperature reaches the TOP limit, the heater may be enabled and the fan disabled, which is why the mode should only be used for Test and Service use.

If the DEC3 has been purchased with DMX/RDM enabled, it is possible to select the required mode 1-3 using RDM. In the RDM context, this is known as selecting the device's DMX PERSONALITY. Setup of the DEC3 from the Front Panel is available in all configurations.



RDM is an effective and powerful tool for commissioning and monitoring an installation, particularly in large systems. For further guidance, we recommend you consult a qualified RDM system integrator. If you don't have one in your neighborhood, go to www.tempestlighting.com, and click on the RDM and RDM Integration bug on the home page for some useful contacts. Tempest Lighting warrants DEC3 to be compliant with the RDM standard, but is not an RDM systems integrator, and can offer only basic guidance on RDM utilization.

DEC3 Control Parameters

DEC3 will run out of the box with its default parameter settings, which equate to the (fixed) settings of its predecessor DEC1 and 2.

Temperature:

Top Set	<i>Range 35-45°C, Default = 40°C</i> Most manufacturers recommend a max temperature for their equipment of 40°C, though this does vary. When DEC3 senses a temperature higher than Top Set, it indicates an overtemp condition as a warning. NOTE: in moving light enclosures the thermal sensor is necessarily placed in the exhaust air path, which will be higher (sometimes a lot higher) than the actual fixture ambient. This needs to be kept in mind when adjusting temperature settings.
Cutoff Temp	<i>Range 0-15°C, Default = 15°C</i> This is a setting <i>above</i> the Top Set temperature that determines the temperature at which the lamp relay is opened, cutting off power from the fixture/projector. The user may reduce it as desired, but should establish before doing so the actual operating temperatures experienced in hot weather before doing so, to avoid nuisance tripping.
Bottom Set	<i>Range 0-10°C, Default = 10°C</i> The temperature maintained by the heater in cold conditions. Most equipment manufacturers recommend a minimum

operating temperature of 0°C, and users may set it lower than the default if desired.

- Humidity Range 50-90%, *Default 80%*
The threshold at which incoming air is more aggressively heated to remove moisture. This parameter will not normally require adjustment.
- DMX Set *Range 001-510, Default 001*
Sets the DMX address for the lamp relay control. In the DMX/RDM service mode, the subsequent two DMX slots control fan and heater respectively.
- Lamp Hours *Default 0000*
DEC3 counts the hours your projector/fixture lamp is on, and can report it both on the user interface display and over RDM. ***Remember to reset to 0 when changing lamps.*** This is provided to allow lamp hours monitoring on devices such as Video Projectors and certain moving lights that have no native RDM or DMX support.

Setup and Connections

Operating Mode Setup

Your DEC3 will normally be factory set to the operating mode you specified in your order:

Operating Mode DIP Switch Settings

Mode	DIPswitch Settings	Mode Summary
Standalone	1-6 OFF	Standalone - no DMX/RDM
DMX/RDM	2 ON, 1, 3-6 OFF	DMX/RDM Modes 1-3 - support for remote monitoring

DMX Connections

DMX refers to USITT DMX512, a commonly used control protocol in the entertainment industry, running over RS485. Consult USITT DMX installation guidelines when laying out a system, or employ a qualified DMX system integrator.

Note that DMX is optional - in many applications it is not required, and need not be connected.

DMX IN - Connect incoming DMX to the 2-part 3-pin terminal on the DEC3 control circuit board so labeled.

Pinout: (1) Ground, (2) Data -, (3) Data +.

DMX THRU - there are two DMX pass-through terminals - one for a fixture inside the enclosure, the other to run to the next DMX device in the network. Pinout: same as DMX IN.

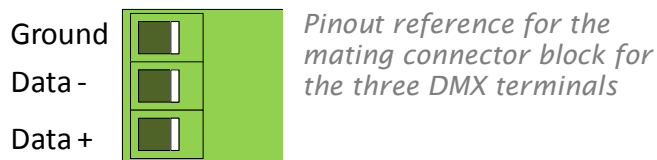
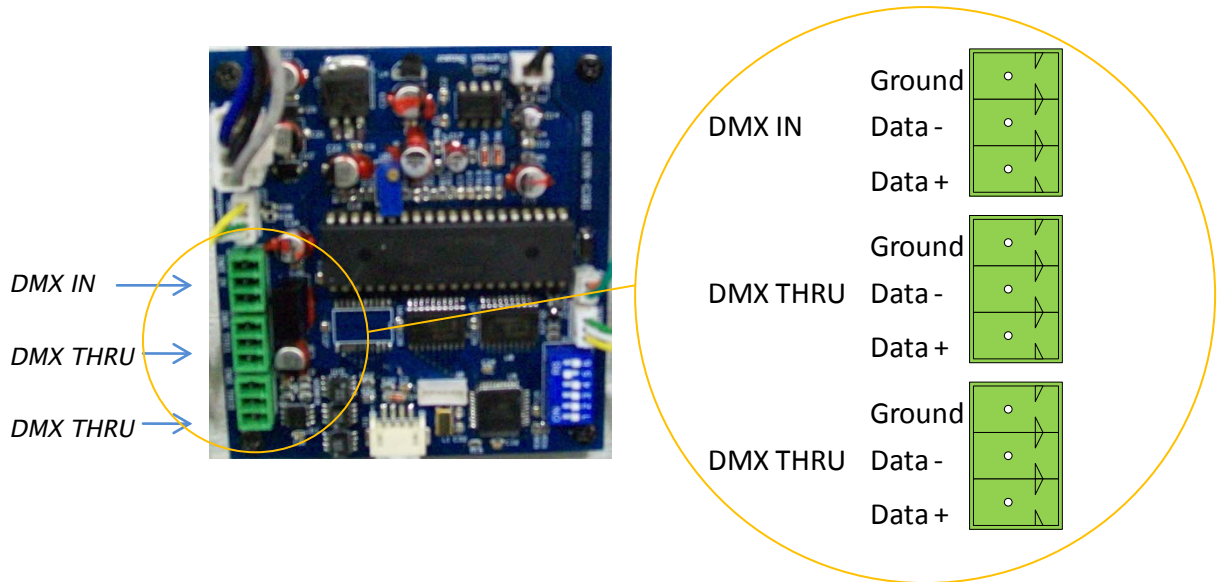

DMX Line Termination

DMX cable runs must be terminated at the far end of the cable run with a termination resistor as detailed in the DMX standard. This is particularly important for satisfactory operation of DMX/RDM installations. The individual fixtures installed inside the Tempest enclosures must NOT be terminated. It is recommended that any line termination is done using the 3-pin terminal connector fitted to the DEC3 control circuit board.

1. Make sure that any DMX termination provided by the fixture inside your enclosure(s) is disabled.
2. The LAST enclosure in the installed DMX daisy chain should have a DMX Termination fitted to one of the pass through DMX connectors. Per the ANSI E1.11 standard, the Terminator shall be 120 ohm +5%/-10% impedance placed between Data+ and Data-. We recommend minimum power rating of 0.6W for the resistor.

We recommend that the installer fit a label externally to say "DMX Termination fitted internally".

Test:

3. Switch mains power OFF to all enclosures.
4. Before connecting the DMX line to your controller, measure the impedance between Pin 2 (Data-) and Pin 3(Data+) at the controller end. Reading should be around 100-130 ohms.

This test shows that you have a terminator in place, and also that you have continuity of Data- and Data+ between installed devices. If the measured resistance is significantly less than 100 ohms, (say 40-80 ohms) it suggests you may have multiple terminations in place. Check that any terminator switches on light fixtures are OFF. If impedance is very low, check for wiring shorts.

RDM Connections

RDM refers to ANSI E1.20, a control protocol in the entertainment industry gaining popularity and essentially an "extension" of DMX512. The use of RDM is optional - but it does require a DMX512 cable connection.

Important – RDM and RDM Integration

RDM (Remote Device Management) is an ANSI standard that adds bidirectional discovery and status monitoring to a standard DMX network connection. No additional wiring is required for RDM operation.

DEC3's RDM implementation allows system integrators to set up remote control and status monitoring of all attributes and sensors, including:

- Temperature
- Humidity
- Lamp Current
- Elapsed Lamp Hours
- Lamp Relay Status
- Fan Relay Status
- Heater Relay Status
- DMX Status
- DMX Start Address
- DMX Personality (RDM Mode)
- Device Type
- Device Label
- Software Version

Tempest Lighting warrants that its RDM products are compliant to the RDM standard, but does not directly support RDM system integration. Tempest Lighting will however provide introductions to qualified RDM system integrators for customers requiring assistance in this area. Links are provided on the Tempest Lighting web site (www.tempestlighting.com).

DEC-3 RDM Supported parameters

DEVICE -INFO
IDENTIFY -DEVICE
DMX -START -ADDRESS
SOFTWARE -VERSION-LABEL
PARAMETER -DESCRIPTION
QUEUED -MESSAGE
STATUS -MESSAGES
STATUS -ID -DESCRIPTION
CLEAR -STATUS -ID
MANUFACTURER -LABEL
DEVICE -LABEL
SENSOR -DEFINITION
SENSOR -VALUE
LAMP - HOURS
DEVICE -MODEL -DESCRIPTION
SLOT -INFO
SLOT -DESCRIPTION
DMX -PERSONALITY
DMX -PERSONALITY -DESCRIPTION
TOP TEMP
BOTTOM TEMP
CUTOFF TEMP

Control Interface

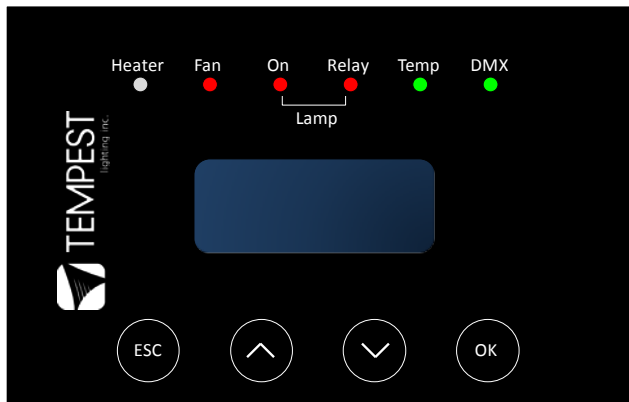

The control interface features a 2-line display, LED indicators, and 4 cap-sense control buttons.

LED Indicators

Heater

SHORT PULSE (RED) - Indicates lamp is off, and the heater is pulsing to prevent condensation inside the enclosure and projector/light fixture. This is normal operation when the lamp is off and the temperature range is above the bottom set limit.

ON (RED) - Indicates heater is on, due to temperature being below bottom temperature setting when lamp is off.

OFF - indicates lamp is on and maintaining temperature above bottom limit.

Fan

SHORT PULSE (RED) - The fan is moving a little air through the enclosure, as part of the condensation prevention strategy. The fan comes on for a few seconds approximately every 30 seconds.

ON (RED) - Indicates fan is running, due to lamp being on or internal temperature exceeding top limit.

Lamp Relay

ON (RED) Indicates lamp relay closed and power is available to the internal fixture/projector.

OFF Indicates lamp relay open and power is removed from the internal fixture.

Lamp On

ON (RED) Indicates current sensed on the lamp circuit greater than 1 amp (this allows some current to be drawn for such things as fans and control electronics without the Lamp On indicator lighting. When the Lamp On indicator is on, the lamp counter is counting lamp life.

Temp

ON (GREEN) - The temperature is between Bottom and Top temperature settings.

FLASHING (RED) - The temperature is above Top setting but has not yet reached the Cutoff level.

ON (RED) - Temperature is above Cutoff level or below Bottom level.

DMX (only used when DMX/RDM setting is in effect)

ON (RED) - DMX error.

ON (GREEN) – Good DMX or RDM data packet received.

Control Interface Operation

The Control Interface is normally LOCKED.
 To UNLOCK, touch ESC and OK together for 5 seconds.
 You are now in the CONTROL MENU
 Use the arrow keys to scroll up and down the menu.
 Use OK, to enter a menu item, then the arrow keys to set the item parameter, or to scroll to the next menu level.
 Use ESC to back up a level, and OK to confirm settings.

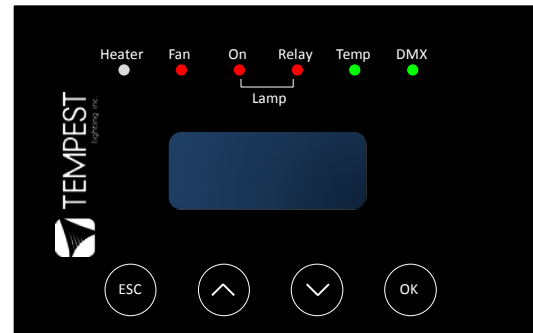

Depending on the Operating Mode selected, and present status, DEC3's display shows you temperature, humidity, DMX address and a selection of error and status messages.

CONTROL MENU

DMX SET (if DMX/RDM mode 2 or 3 is selected)

Select a DMX starting address in the range 001 to 510

1 – Lamp Relay

In RDM Mode 3 an addition two slots are required

2 – Fan Relay

3 – Heater Relay

Note that the DMX control is designed using a SAFETY pile-on Logic. In other words, the DMX input can only override automatic settings in a safe manner. For example, if the enclosure has switched off the lamp relay due to an over-temperature condition, the DMX input cannot switch it on, if the fans are running because of Overtemp, the DMX input cannot turn them off, and so on.

The DMX SET menu can be ignored if the DEC3 is in Standalone or DMX/RDM Mode 1 (RDM Monitor) mode.

SET LAMP HOURS TO 0

The lamp hour counter needs to be reset each time you change the lamp in the fixture/projector. Make this a part of your maintenance instructions.

STATUS DISPLAY

View Temperature (in Celsius) and Relative Humidity (in %) inside the enclosure. Note that in Tornado moving light enclosures the temp/humidity sensor is located in the exhaust airflow, which may be significantly warmer than ambient.

HUMIDITY SET

The humidity level above which the heater kicks in to remove humidity from incoming air (default 80%, permissible range 50-90%). This setting should not normally be changed.

TEMP SET

Set three temperature trigger points for Top, Cutoff and Bottom temperatures.

TOP TEMP

The desired upper temperature limit for normal operation (default 40°C, permissible range 35-45°C).

When the DEC3 sees air above this temperature, but below the additional Cutoff temperature (see below), it indicates a temperature error. This is not dangerous, but may reduce lamp life.

CUTOFF TEMP

The desired upper temperature ABOVE the TOP TEMP setting, at which the lamp relay is forced to open, isolating the fixture/projector power.

(default 15°C, permissible range 0-15°C).

To avoid nuisance tripping, set this variable to the maximum, and monitor actual temperatures in your normal operating conditions. If your actual temperatures are running lower, then you may reduce the cutoff temperature margin. In hot climates, it may be advisable to set both TOP TEMP and CUTOFF TEMP as high as possible.

BOTTOM TEMP

The desired lower temperature limit for normal operation

(default 10°C, permissible range 0-10°C).

Note that a higher BOTTOM TEMP may provide additional protection against condensation in some conditions, but will consume more energy. Therefore a lower setting is desirable, provided the user is certain that no condensation is occurring.

RDM MODE SET

The RDM Mode is normally set using RDM commands from a remote RDM control device to set the DMX PERSONALITY of the DEC3.

From the DEC3 user interface, this menu item allows the user to check (and if necessary alter) the RDM mode. Please ensure that the DEC3 is NOT unintentionally left in Mode3 (Service/Test).

5 Mounting the Luminaire – Tornado 2000, 2200, 2300

Having mounted and wired the enclosure, the next step is to mount the luminaire into it. More specific instructions are given in the luminaire-specific instructions

-  Do not attempt to mount the luminaire with only a single person. Handling the luminaire safely requires two people.
- 1 If the globe is on the enclosure, remove it and place it in a safe location.
- 2 Make sure that the power switch of the luminaire is in the off position.
- 3 Carefully load the luminaire into the enclosure and hold in place so that the holes line up.
- 4 Place appropriate bolts through holes as indicated in the luminaire-specific instructions. Tighten bolts down to hold luminaire in place.
- 5 Safety cable the luminaire to the box yoke of the enclosure.
- 6 Plug the luminaire into the power receptacle in the enclosure, and then connect the DMX cables to the luminaire
- 7 Tie down cables (to luminaire or mounting brackets) so that they will not come into contact with the heater or fans at any point.

The Fixture Tray comes pre-punched with mounting holes for the most popular luminaire types. Most luminaires mount using manufacturer-provided omega clamps, and some bolt directly through the fixture tray into the base of the fixture. The following chart is a guideline for some of the most commonly used luminaire types. For luminaires not shown, and which cannot for any reason be mounted using omega clamps, please contact us.

Tornado 2200/2300	Clay Paky 1200 Spot	Clay Paky 1500 Beam	Martin MAC3	Martin MAC2000	Vari*Lite VL3000	Vari*Lite VL3500W	Robe 1200AT	Robe 2500AT	Robe 700 Beam
Omega Clamp	yes	yes	no	yes	no*	no*	yes	yes	yes
Omega Clamp Spacer	1in, 25mm	1in, 25mm	no	1in, 25mm	no	no	1in, 25mm	1in, 25mm	1in, 25mm

Tornado 2000	Martin MAC700W	Martin 575 Krypton	Martin MAC600	Martin MAC700	Robe Wash 575 AT	Robe Colorsport 575
Omega Clamp	yes	yes	yes	yes	yes	yes
Omega Clamp Spacer	1in, 25mm	1in, 25mm	1in, 25mm	1in, 25mm	1in, 25mm	1in, 25mm

* Vari*Lites use their own Hook Rail in place of an Omega Clamp.

The Fixture Tray

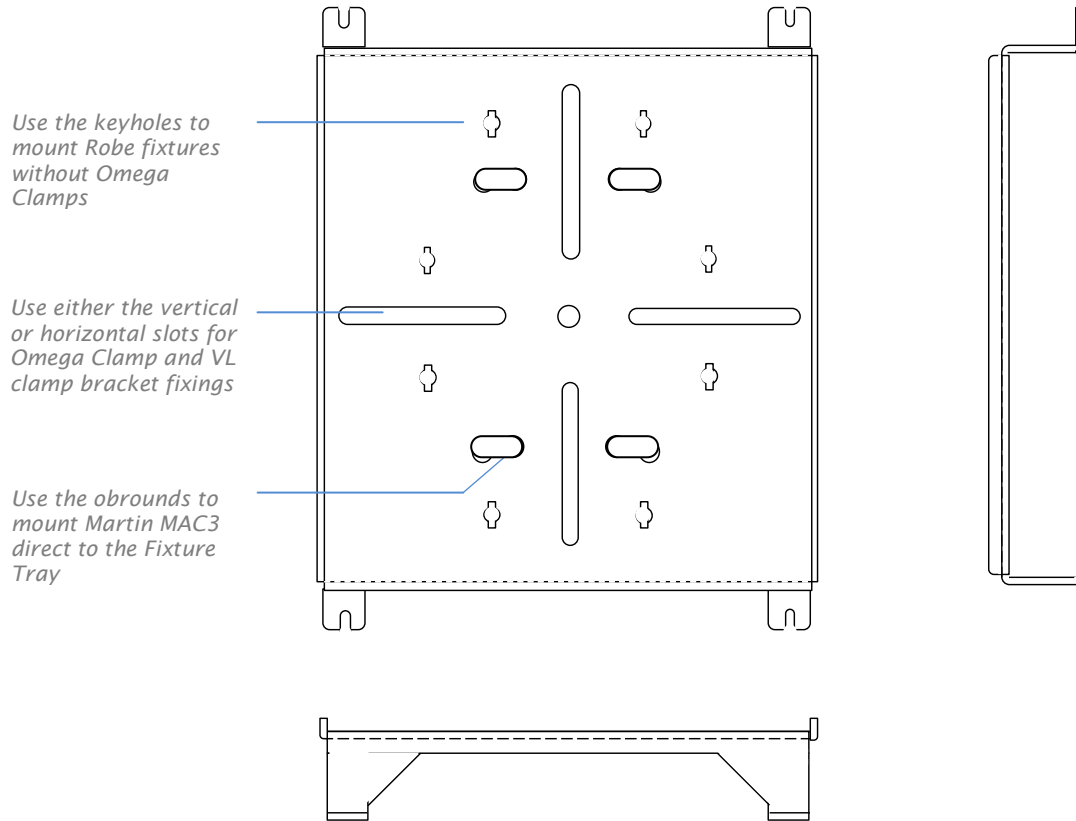

Luminaires with Omega Clamps

This applies to most luminaire types – see illustration overleaf:

1. Remove the Fixture tray from the enclosure, by removing the four 5/16" bolts holding it in place.
2. Look at the base of your fixture – it will have multiple locations for the Omega clamps. Pick two that are oriented either side-to-side or front-to-back, and mount the Omega clamps securely onto the fixture base, in two of the slots provided. Do not use 45° clamp positions. Be sure that the quarter-turn fasteners lock positively in place.
3. Bolt the clamps to the fixture tray, using the Omega Clamp Spacers and the bolts provided. **CHECK THAT THE FIXTURE IS CENTERED ON THE FIXTURE TRAY.**
4. Replace the fixture tray/fixture assembly in the enclosure, and bolt firmly in place.

Diagram – Mounting with Omega Clamps and Clamp Spacers

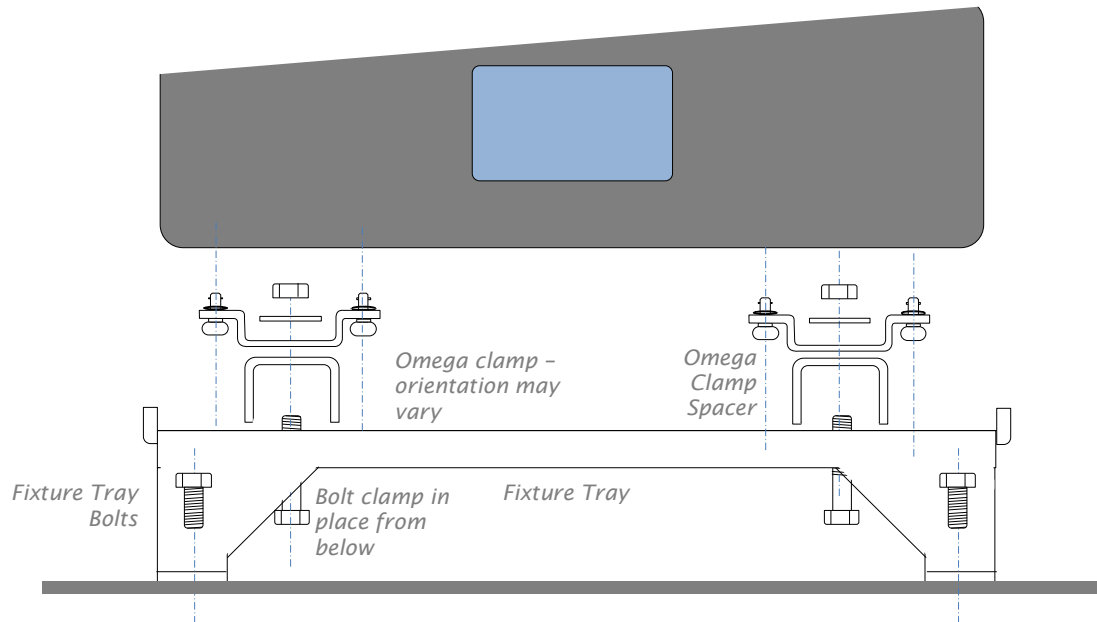

Variant – Vari*Lites and Vari*Lite Hook Bracket

Vari*Lites are provided with a Hook Bracket in place of an Omega Clamp.

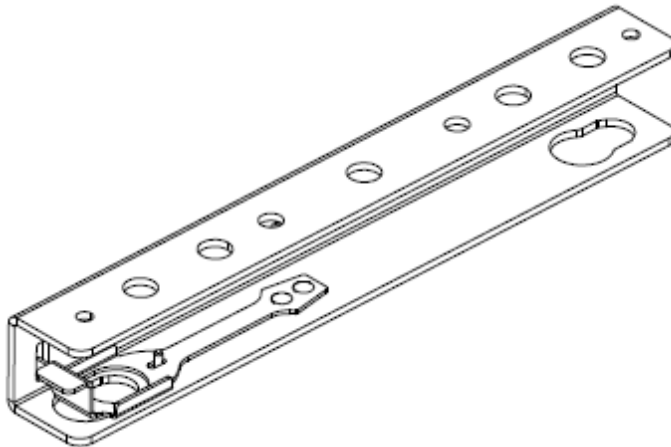

1. Attach the Hook Bracket to the VL fixture feet, following instructions provided by Vari*Lite.
5. Remove the Fixture tray from the enclosure, by removing the four 5/16" bolts holding it in place.
6. Bolt the Hook Brackets to the fixture tray, using the bolts provided. CHECK THAT THE FIXTURE IS CENTERED ON THE FIXTURE TRAY.

Replace the fixture tray/fixture assembly in the enclosure, and bolt firmly in place.

Martin MAC III, and other Luminaires without Omega Clamps

The MACIII is too tall to use in a Tornado 2300 with Omega Clamps. In this case, and in other cases where Omega Clamps may be undesirable, the fixture must be secured in place with quarter-turn fasteners.

1. Remove the Fixture tray from the enclosure, by removing the four 5/16" bolts holding it in place.
2. Identify the mounting holes in the Fixture Tray that line up with the fixture mounting locations.
3. Using a hammer, knock out the pin from the quarter-turn fasteners supplied in the fixture's omega clamps, remove them from the omega clamp, and re-assemble them on the fixture tray, as shown below.

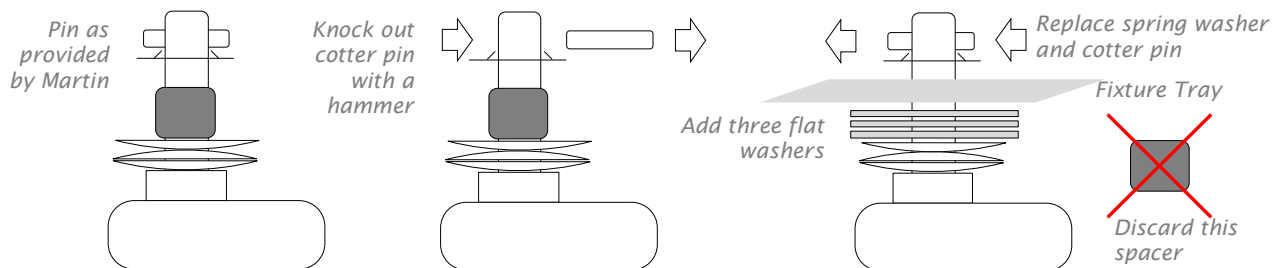

- a) Use a hammer to knock the cotter pin out of the four quarter-turn fasteners supplied with the MACIII, and remove them from the Omega Clamps.
 - b) Remove the spring washer and spacer.
 - c) Add three 1/2" flat washers supplied with the Tornado enclosure to the quarter-turn pin
 - d) Insert the pin through the fixture tray from below
 - e) Replace the spring washer and the cotter pin
4. Carefully place the fixture on its side on a flat surface, and locate the quarter-turn pins into the receptacles in the fixture base:



5. Replace the fixture tray/fixture assembly in the enclosure, and use the quarter-turn fasteners to secure firmly in place

Diagram – Mounting with Quarter-turn Fasteners

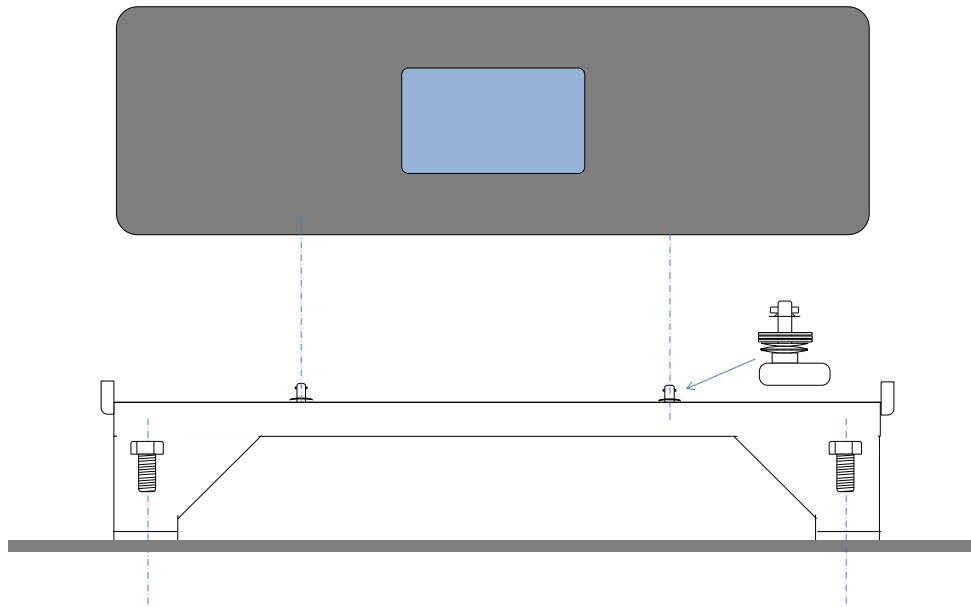

Luminaires Requiring Bracket Standoffs

In order to align the center of the luminaire correctly in the Tornado enclosure, some fixtures need the Fixture tray to be raised. This is done with tubular standoffs that insert between the Fixture Tray and the enclosure Base. The installation procedure is the same as for any of the above, except that the fixture standoffs must be inserted when the Fixture Tray is remounted.

If the fixture you specified when you ordered your Tornado enclosure requires bracket standoffs, they will have been supplied. If none are supplied, your fixture does not require them.

Diagram – Fixture Tray Standoffs

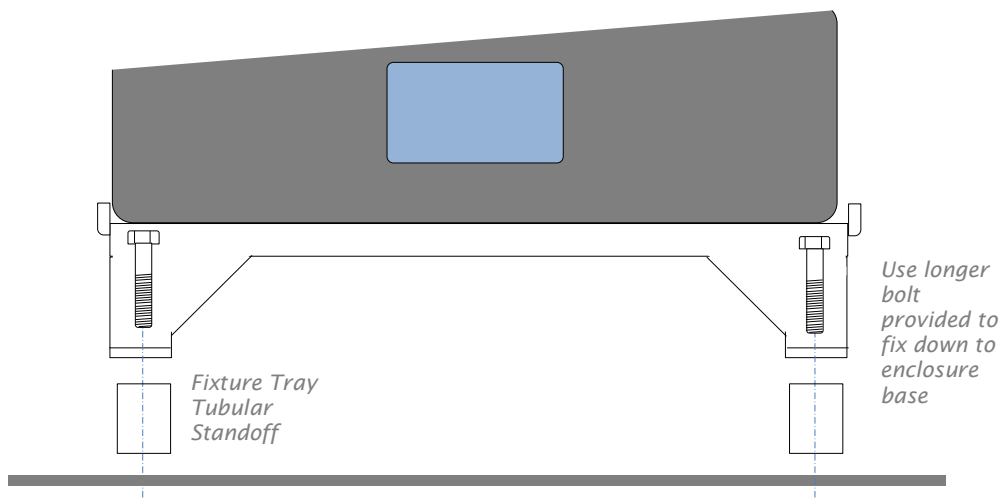

5.1 Mounting the Luminaire - Tornado 2050

The Tornado 2050 is designed for most moving head luminaires up to 300W, using one or two omega clamps (supplied with the luminaire) to install.

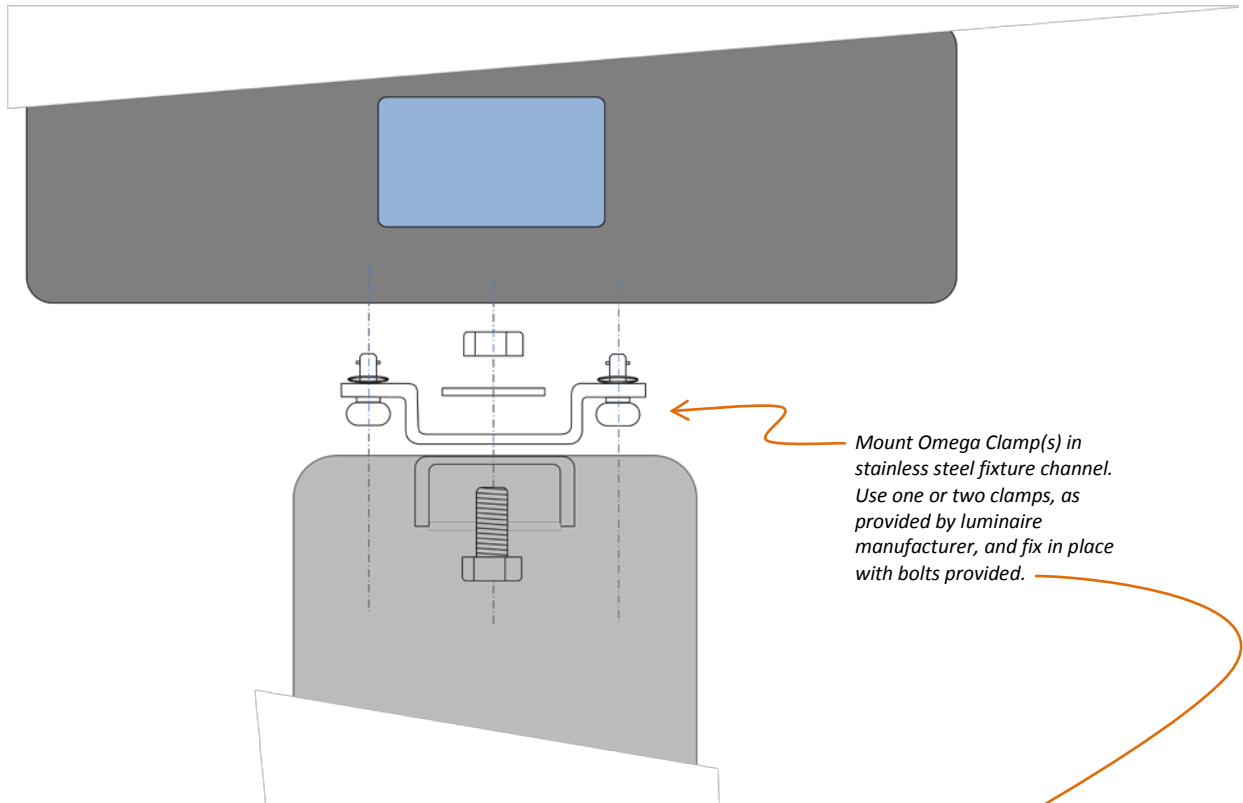

Mount Omega Clamp(s) in stainless steel fixture channel. Use one or two clamps, as provided by luminaire manufacturer, and fix in place with bolts provided.

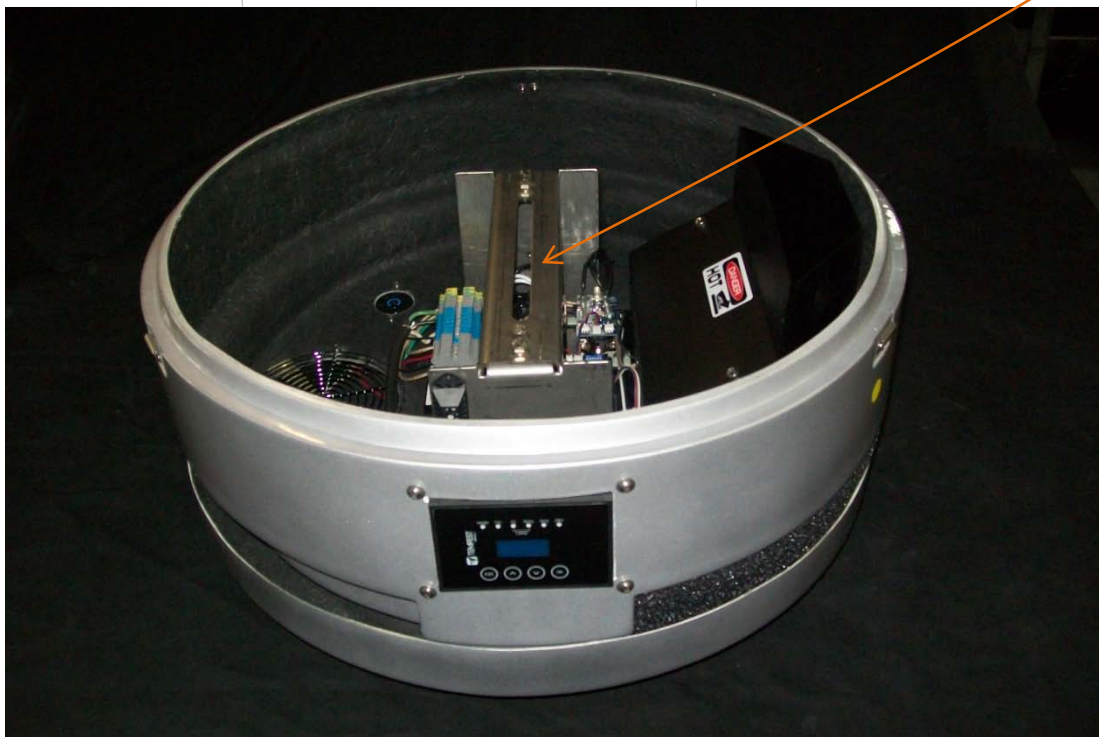

5.2 Mounting the Luminaire – Tornado 2400

The Tornado 2400 is designed to house the Barco/High End Systems Showgun, Showbeam, Showpix and DL3 luminaires, all of which have the same base.

The Tornado 2400 is supplied with two heavy-duty mounting brackets, through which the four quarter-turn fasteners supplied with the luminaire lock into the fixture base.

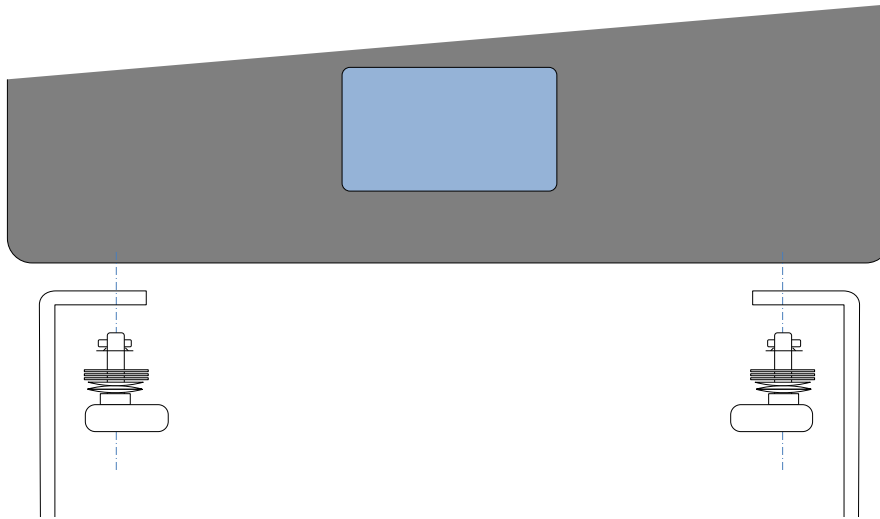

5.3 Closing up the Enclosure

Now, complete and check all electrical connections as described elsewhere in this manual, and complete DMX control connections in accordance with fixture manufacturer's instructions.

- Safety cable the luminaire to the box yoke of the enclosure.
- Tie down cables (to luminaire or mounting brackets) so that they will not come into contact with the heater or fans at any point.

When you are satisfied that the fixture is properly connected, you may replace the globe assembly on the Tornado base.

Attaching the Globe to the Tornado Enclosure Base

You must use at least two people for this operation. The globe is not heavy, but is susceptible to wind gusting until secured in place.

1. Using two people, lift the globe assembly in place. Be sure to align the yellow dots, to ensure best fit. The four latches are pre-tensioned in the factory, and the best seal will be assured if correct alignment is observed.
2. As soon as the globe assembly is in place, secure the four latches, and insert padlocks in the locking rings, if required, for additional security.
3. **IMPORTANT NOTE: The latch tension is adjustable, and has been set in the factory to assure a secure and weathertight seal. If for any reason the tension adjustment is loosened by the installer, it is possible that the latch might become loose and detach in high wind. If you do loosen it for any reason, be sure to re-tighten until a positive latch is attained.**



Latch properly secured, with a carabiner in place. Use a padlock (not supplied) for greater security if preferred.



Detail showing tension screw and locknut. This has been adjusted and locked in the factory for correct tension and an airtight seal. Do not tamper with the locknut. If setting is changed for any reason, check for tight fit before completing the installation.

Congratulations! Your system is now ready to check out.

6 Activation and Checkout

-  When the enclosure is powered, the heater will get hot and the fans will turn periodically (see section 4). Keep hands and any other objects away from these areas before applying power.
- 1 Clear the enclosure and luminaire of all debris. If your enclosure is being powered by only one supply line, skip to Step 5.
 - 2 Make sure that the power switch on the luminaire is in the on position.
 - 3 **If the enclosure has been connected with two power supply lines**, turn on the supply for the luminaire. If connected properly, nothing should appear to turn on at this point. Because of the automatic luminaire shutdown feature when the climate control is not functioning, the luminaire should not come on. If the luminaire or temperature control unit comes on, shut off the power and check your supply line wiring. If the supply line wiring is correct, contact technical support for assistance. If everything is working properly, shut off the power and continue to the next step.
 4. **If the enclosure has been connected with two power supply lines**, turn on the supply for the enclosure. The control panel will cycle through its initialization sequence and then display the internal temperature (in °C) Humidity (in %) and DMX address, if DMX mode is active. The heater indicator should be flashing, and the fans will turn for a few seconds approximately every 30 seconds. If all is operating correctly, turn on the supply for the luminaire and proceed to Step 6.
 - 5 **If the enclosure has been connected with only one power supply line**, turn on the supply. The control panel will cycle through its initialization sequence and then display the internal temperature (in °C) Humidity (in %) and DMX address, if DMX mode is active. The heater indicator should be flashing, and the fans will turn for a few seconds approximately every 30 seconds. If all is operating correctly, turn on the luminaire power switch. If temperature is in the normal range (see section 4), your fixture should start. Proceed to Step 6.
 - 6 The exact status of the luminaire depends on the DMX signal present, but there should be an indication that power is connected to it. If no indication is present, shut down **all** power supplies and check your wiring. If it is present, continue to the next step.
 - 7 Test the luminaire by sending DMX signals to it, in accordance with the luminaire manual. If it does not respond, check your DMX control wiring. If it responds properly, continue to the next step.
 - 8 Place the globe back on the enclosure and lock it down. The installation is complete.

Note

Enclosure can be locked with a padlock at this time. Only qualified personnel should be accessing the enclosure.

7 *Operation*

- ① Enclosure must receive power at all times. It is an active, climate-controlled enclosure, and will not provide proper protection for the luminaire inside if it is not connected to AC power.
- ① Unless the enclosure or luminaire is undergoing routine maintenance, the globe should be in place and locked down at all times.
- ① Only authorized personnel should open the enclosure (see maintenance warnings in the next chapter).
- ① If the ambient temperature is high enough, the over-temperature shutdown feature may engage and temporarily cut off power to the luminaire. Once the temperature reaches acceptable levels, power will be automatically restored.
- ① **Do not** routinely operate luminaire in full sun in warm weather. Black luminaires absorb a significant amount of energy from the sun and may overheat in these conditions. The enclosure has not been designed to protect the luminaire when running in this kind of extreme condition (keep in mind outside lighting is generally used at night).





8 Routine Maintenance

It is very important to perform routine maintenance on both the enclosure and the luminaire within. Failure to do so may reduce lifetime for both the enclosure and the luminaire.

Note

Maintenance schedules depend on location and environment. The times given here are simply general minimum guidelines for you to use. It is up to you to judge whether maintenance should be done more often. We do advise doing these tasks no less often than mentioned here.

Safety

-  As the enclosure is a powered unit with moving parts, it is necessary to keep safety in mind while performing routine maintenance. Although maintenance can be performed while the enclosure is powered, it is safer to carry it out with the power disconnected with proper lockout and tag out procedures followed.
-  Be aware that once the enclosure has had power applied to it, the heater will get hot and the fans will start to turn. Make sure that your hands are clear of these areas before applying power to the enclosure.
-  Only authorized personnel should perform maintenance on the enclosure or luminaire
-  Do not service the unit in the rain or other adverse weather conditions (snow, sleet, high winds, etc.).
-  Be aware that the globe is a large object that can be awkward to handle, especially when standing on a ladder or scaffolding.

Inspection Checklist: - Every Three (3) Months

- All weep (drain) holes should be clear
- All vents should be free of debris
- Enclosure should be free of debris both inside and out
- Bolts should be tight
- All safety cable should be in good condition
- Lid seal should be in good condition, Check seal inside and out for gaps.
- Globe should not be cracked
- Fans should be moving (it will be necessary to have the power on to check this), with corresponding indicator status

Except for the last two items (concerning globe and fan), problems with any of these things can be easily remedied. Contact technical support for problems with the last two items.

Air Filters - Every Three (3) Months

The air filters all around the base should be removed and cleaned on a regular basis. To remove filters, pull them directly out of their grooves. The filters can be cleaned by running water from a hose and do not require any special solution.

To reinstall, push filter back into place between the top and bottom base covers.

Case and Globe - As Needed

The outside of the case and globe should be cleaned as needed. Outside inspection should give you a good idea of when this is necessary. The case should be cleaned with a wet cloth and mild detergent (if necessary). Do not use a direct spray from a hose to clean the case. The globe can be cleaned with any mild cleaner. It is also acceptable to treat globe with a product that keeps rain from adhering to its surface.

DO NOT USE hydrocarbon-based cleaners on the globe under any circumstances. They can severely damage the globe material.

Luminaire

Review the manufacturer's instructions for proper maintenance of your luminaire. Remember, the enclosure simply protects the luminaire and is not a substitute for regular maintenance.

9 Troubleshooting

This is a guide to the general symptoms, problems, and solutions that may occur during the lifetime of your enclosure. However, it is important to remember that problems may occur within the luminaire itself and these must also be considered.

Luminaire does not have power.

Check power switch of luminaire. (Note: the following actions should be performed by a licensed electrician) If power is on, check wiring (including metering supply voltages, enclosure must receive 200-240VAC to operate properly). If LEDs on the DEC3 control panel controller are lit, check the Lamp Relay LED. If it is on, meter power in receptacle. If no power is present at the receptacle, contact technical support.

In case of over-temperature, the power disconnection is an intended function of the enclosure and is for the protection of the luminaire, which is not meant to operate in extreme conditions. In this case, the problem will only continue until temperature drops to acceptable levels. It is possible that the air intake or exhaust has become clogged, leading to higher temperatures inside the enclosure. Make sure that these areas are clear, the filters are clean, and the fans are working properly.

Luminaire turns on and off repeatedly

Check that vent areas and airways are clear. If so, ambient temperature may be too high (see over-temperature note above) or luminaire may have internal problem.

Luminaire does not respond to DMX signal.

Make sure that luminaire has power. If so, check DMX wiring. If not, see above.

Fans are not spinning.

Fan cords may have become disconnected. Check connections between fan and cord.

Fans may be obstructed. Shut off power to enclosure and check for obstructions. Turn power back on to see if fans will start spinning. If fans do not turn and display on temperature controller is lit, contact technical support. If fans do not turn display is not lit, then enclosure is not receiving power. Turn off all power and check wiring. If the wiring is correct, contact technical support.

Excessive debris in unit.

Filter may not be fully pushed into groove. Make sure that it is in place around the whole unit.

Excessive water in enclosure.

Weep (drain) holes may be clogged. Clear them.

Latches do not latch properly.

Closure of globe may be obstructed. Check to make sure perimeter is clear before replacing globe.

10 Sample Specification

Unit shall be a Tempest Lighting Tornado 2____. The housing shall be 0.090” thick aluminum plate, treated with exterior-grade epoxy dry powder coating, and finished with a UV-blocking clear-coat. Further, the unit shall possess filtered forced air ventilation in combination with heater and controlled by a microprocessor with a temperature display. Unit shall be ETL listed to U.L. standard 508 for wet locations and be a NEMA type 3R. The unit shall have above ground connection ports, compression latches with padlock rings, and may be secured to its mounting via stainless steel eye bolt, making it highly theft resistant. Unit shall provide a power cutoff to fixture in case of high temperature inside enclosure. Units shall control cool-down rate of lighting fixture by use of heater. Unit shall have a projection globe with 360° of pan and 260° of tilt. The fixture shall be identified as The Tornado Enclosure manufactured by Tempest Lighting, Inc., of North Hollywood, CA, USA.

11 Limited Warranty

What is covered. Exclusions.

Unless otherwise stated, your product is covered by a one (1) year parts and labor limited warranty. Factory-painted product is not guaranteed against scratches. It is the Owner's responsibility to furnish receipts or invoices for verification of purchase date, and dealer or distributor. If purchase date cannot be provided, date of manufacture will be used to determine start of warranty period. Unless otherwise specifically stated in writing, all warranty work is carried out at the Tempest Lighting factory. In the event that the Owner purchases any optionally available on-site check-out or turn-on services, Owner agrees to provide facilities to perform such services at ground level. Tempest Lighting does not in any way offer any warranty for the luminaire.

Owner Responsibility for Installation.

Tempest Lighting makes no recommendations for mounting any Tempest Lighting product. It is the sole responsibility of the Owner to perform any necessary structural, electrical, environmental or other appropriate analysis prior to installing any Tempest Lighting product.

Returning an Item Under Warranty for Repair.

It is necessary to obtain a Return Material Authorization number (RMA#) from your dealer or point of purchase BEFORE any units are returned for repair. The manufacturer will make the final determination as to whether or not the unit is covered by warranty.

Any Product unit or parts returned to Tempest Lighting, Inc., must be packaged in a suitable manner to ensure the protection of such Product unit or parts, and such package shall be clearly and prominently marked to indicate that the package contains returned Product units or parts and with a Return Material Authorization (RMA#) number. Accompany all returned Product units or parts with a written explanation of the problem or malfunction.

***NOTE:** Freight Damage Claims are invalid for fixtures shipped in non-factory boxes and packing materials. These materials can be supplied if requested, at additional cost. It is recommended that all packaging material be retained for possible re-use.*

Freight.

All shipping charges must be prepaid by the Owner. Items under warranty shall have return shipping paid by the manufacturer only in the Continental United States. Under no circumstances will freight collect shipments be accepted. Prepaid return shipping does not include expediting such as airfreight. Airfreight will ship customer collect.

REPAIR OR REPLACEMENT AS PROVIDED FOR UNDER THIS WARRANTY IS THE EXCLUSIVE REMEDY OF THE CONSUMER. TEMPEST LIGHTING, INC. MAKES NO WARRANTIES, EXPRESS OR IMPLIED, WITH RESPECT TO ANY PRODUCT, AND TEMPEST LIGHTING SPECIFICALLY DISCLAIMS ANY WARRANTY OF MERCHANTABILITY OR FITNESS FOR A PARTICULAR PURPOSE. TEMPEST LIGHTING SHALL NOT BE LIABLE FOR ANY INDIRECT, INCIDENTAL OR CONSEQUENTIAL DAMAGE, INCLUDING

LOST PROFITS, SUSTAINED OR INCURRED IN CONNECTION WITH ANY PRODUCT OR CAUSED BY PRODUCT DEFECTS OR THE PARTIAL OR TOTAL FAILURE OF ANY PRODUCT REGARDLESS OF THE FORM OF ACTION, WHETHER IN CONTRACT, TORT (INCLUDING NEGLIGENCE), STRICT LIABILITY OR OTHERWISE, AND WHETHER OR NOT SUCH DAMAGES WERE FORESEEN OF UNFORESEEN.

Warranty is void if the product is misused, damage, modified in any way, or where unauthorized repairs or parts have been employed. This warranty gives you specific legal rights, and you may also have other rights, which vary from state to state.

Tempest Product Support.

Step 1: First contact your local Dealer for support. Your dealer is best placed to respond quickly to your needs.

Step 2: If your dealer is unable to answer your questions please contact

Tempest Lighting
13110 Saticoy Street
North Hollywood, CA 91605, USA
Tel +1 818 787 8984
Fax +1 818 982 5582
info@tempestlighting.com

Visit our web site for current information and specifications:

www.tempestlighting.com

12 Registration

Filling out the registration form on the next page and sending it to the Tempest Lighting factory within 30 days of installation entitles you to the warranty cover specified in this manual. It also enables us to notify you in case of important news or post-sale information regarding the Tornado Lighting Enclosure.

Tornado Enclosure Registration Form

Detach and mail/fax to:

Tempest Lighting, Inc., 13110 Saticoy St., N Hollywood, CA 91605

Fax # +1 818 982 5582

If a Tempest Representative has not inspected the installation, please send photos showing installation.

Model Number:

Serial Number:

Latch Key Number:

Dealer/Sold By

Name:

Location:

Date Purchased:

Contractor/Installed By

Name:

Date Installed:

Location Installed:

Company/Organization

Name:

Street Address:

City, State, ZIP, Country:

.....

Phone:

Fax:

Contact Information

Name:

Phone:

Extension:

Fax:

E-mail: